

One Touch 4.0  
January 2009  
05-0782-000



# DocuMate 700

## User's Guide



Design © 2009 Xerox Corporation. All rights reserved. Xerox®, and the sphere of connectivity design are trademarks of Xerox Corporation in the United States and/or other countries.

Content © 2009 Visioneer, Inc. All rights reserved. The Visioneer brand name and logo are registered trademarks of Visioneer, Inc.

Reproduction, adaptation, or translation without prior written permission is prohibited, except as allowed under the copyright laws.

The PaperPort® and OmniPage® brand name and logo are registered trademarks of Nuance Communications, Inc. QuickScan™ is a trademark and ISIS® is a registered trademark of EMC Corporation.

Kofax® and Virtual ReScan® are registered trademarks, and VRS™ is a trademark of Kofax Image Products, Inc.

Adobe®, Adobe® Reader®, Acrobat® Reader®, Adobe® Acrobat®, and the Adobe® PDF logo are registered trademarks of Adobe Systems Incorporated in the United States and/or other countries. The Adobe PDF logo will appear in this product's software, and full access to Adobe software features is only available if any Adobe product is installed on your computer.

Microsoft is a U.S. registered trademark of Microsoft Corporation. Windows™ is a trademark and SharePoint® is a registered trademark of Microsoft Corporation.

ZyINDEX is a registered trademark of ZyLAB International, Inc. ZyINDEX toolkit portions, Copyright © 1990-1998, ZyLAB International, Inc.

All Rights Reserved. All other products mentioned herein may be trademarks of their respective companies.

Changes are periodically made to this document. Changes, technical inaccuracies, and typographic errors will be corrected in subsequent editions.

Document Version: 05-0782-000 (January 2009).

Information is subject to change without notice and does not represent a commitment on the part of Visioneer. The software described is furnished under a licensing agreement. The software may be used or copied only in accordance with the terms of such an agreement. It is against the law to copy the software on any medium except as specifically allowed in the licensing agreement. No part of this document may be reproduced or transmitted in any form or by any means, electronic or mechanical, including photocopying, recording, or information storage and retrieval systems, or translated to another language, for any purpose other than the licensee's personal use and as specifically allowed in the licensing agreement, without the express written permission of Visioneer.

#### Restricted Rights Legend

Use, duplication, or disclosure is subject to restrictions as set forth in contract subdivision (c)(1)(ii) of the Rights in Technical Data and Computer Software Clause 52.227-FAR14. Material scanned by this product may be protected by governmental laws and other regulations, such as copyright laws. The customer is solely responsible for complying with all such laws and regulations.



# Table of Contents

<b>Welcome</b> .....	<b>v</b>
Before You Begin .....	v
Documentation .....	vi
System Requirements .....	vi
The Xerox DocuMate 700 Scanner .....	vii
<b>1 Installation</b> .....	<b>1-1</b>
Step 1: Install the Software .....	1-2
Step 2: Connect the Scanner .....	1-7
Step 3: Register Your Scanner .....	1-11
Additional Applications Available with Your Scanner .....	1-12
View the User Guides .....	1-13
Scanning Interfaces .....	1-14
<b>2 Scanning From One Touch</b> .....	<b>2-15</b>
Default One Touch Settings .....	2-16
Scan using the One Touch button .....	2-17
Scan from the One Touch Button Panel .....	2-18
Features of the One Touch Button Panel .....	2-19
Configuring the One Touch Buttons .....	2-20
Selecting New Settings .....	2-21
Creating a New Scan Configuration .....	2-23
Editing or Deleting Scan Configurations .....	2-29
Configure Before Scan .....	2-29
Selecting Document and File Format Options .....	2-32
Selecting Options for One Touch .....	2-36
Setting Destination Application Properties .....	2-37
Special Features and Scanning Destinations .....	2-43
Scanning with Optical Character Recognition (OCR) .....	2-43
Scan and Burn to a CD .....	2-44
Scanning with Event Forwarding (STI) .....	2-45
Creating an HTML Web Page from Your Scanned Documents .....	2-46
Transferring Scanned Documents to Storage .....	2-47
Checking the Hardware and Setting the Lamp Power Saving .....	2-51
<b>3 Scanning from TWAIN</b> .....	<b>3-53</b>
Accessing the TWAIN Interface .....	3-54

- The Two TWAIN Interface Options ..... 3-55
  - Scanning from the TWAIN Basic Interface ..... 3-56
  - Scanning from the TWAIN Advanced Interface ..... 3-58
  - Adjusting the Image with the Advanced Interface ..... 3-59
  - Adjusting the Resolution ..... 3-60
  - Adjusting the Brightness and Contrast ..... 3-61
  - Adjusting Gamma, Saturation, and Color Hue ..... 3-62
  - Adjusting Input Size ..... 3-63
  - Creating a New Advanced Interface Profile ..... 3-65
- Connect to Another Scanner ..... 3-66
  - Scanning from the Automatic Document Feeder ..... 3-69
- 4 Scanning from WIA ..... 4-73**
  - Fine Tuning Your Scans ..... 4-74
- 5 Scanning from ISIS ..... 5-77**
- 6 Maintenance ..... 6-79**
  - Cleaning the Scanner Glass ..... 6-79
  - Troubleshooting ..... 6-79
    - Error Light Troubleshooting Codes ..... 6-81
  - Uninstalling Your Scanner ..... 6-82
  - DocuMate 700 Scanner Specifications ..... 6-83
  - Xerox DocuMate 700 Parts List ..... 6-84
- 7 Appendices ..... 7-85**
  - Appendix A: Safety Introduction ..... 7-85
  - Appendix B: EMC ..... 7-85
  - Appendix C: Operational Safety Information ..... 7-86
  - Appendix D: Electrical Information ..... 7-87
  - Appendix E: Emergency Power Off ..... 7-88
  - Appendix F: Maintenance Information ..... 7-88
  - Appendix G: Product Safety Certification ..... 7-88
  - Appendix H: Regulatory Information ..... 7-89
  - Appendix I: Compliance Information ..... 7-89
  - Appendix J: Illegal Copies ..... 7-91
  - Appendix K: EH&S Contact Information ..... 7-93
- 8 Index ..... 8-95**

# Welcome

Congratulations on purchasing your Xerox DocuMate 700. With this scanner you can quickly scan paper items such as letters or receipts and place their electronic images on your computer. With its innovative USB pass through, you can connect to another Xerox desktop scanner to add the functionality of that scanner to the TWAIN interface of the DocuMate 700.

## Before You Begin

Before starting the software installation, please check the contents of the box to make sure that all parts are included. If any items are missing or damaged, contact the dealer where you purchased the scanner.



DocuMate 700 Scanner



USB Cable



Power Cable



Power Supply



Installation Disc

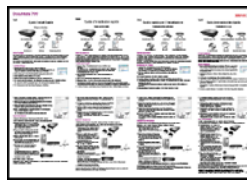

Quick Install Guide

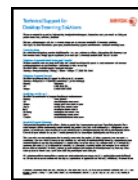

Technical Support Card

# Documentation

The following documentation is provided with your scanner:

- Quick Install Guide—Abbreviated installation instructions.
- Scanner User's Guide—On the Installation Disc; contains detailed installation, scanning, configuration, and maintenance information.
- Mini-Guides—On the Installation Disc; contains detailed instructions on using the One Touch OmniPage module, One Touch VRS module and SharePoint destination link.
- Readme—Contains the latest information about your scanner and software installation.
- PaperPort User's Guide—On the Installation Disc; contains detailed feature and configuration information for the PaperPort software.
- OmniPage User's Guide—On the Installation Disc; contains detailed feature and configuration information for the OmniPage software.
- QuickScan User's Guide—On the Installation Disc; contains detailed instructions for using the software.
- Online Help—For the scanner configuration, TWAIN and WIA interfaces, and PaperPort software applications.

# System Requirements

## **IBM-compatible Pentium 4 PC, or AMD equivalent with:**

- A DVD-ROM drive
- An available Universal Serial Bus (USB) port
- Microsoft® Windows® operating system: Windows 2000 (Service Pack 4), 32-bit Windows XP (Service Pack 2), 32-bit or 64-bit Windows Vista  
The scanner is compatible with Service Pack 3 for Windows XP and Service Pack 1 for Windows Vista.
- *Windows 2000 and XP:* Minimum of 512 megabytes (MB) of internal memory (RAM)  
*Windows Vista:* Minimum of 1 gigabyte (GB) of internal memory (RAM)
- 350 MB minimum of free hard disk space

## **A VGA or SVGA Monitor**

The recommended settings for your monitor are:

- Color quality of 16-bit or 32-bit
- Resolution set to at least 800 x 600 pixels

Refer to your Windows documentation for instructions on setting the color quality and resolution for the monitor.

# The Xerox DocuMate 700 Scanner

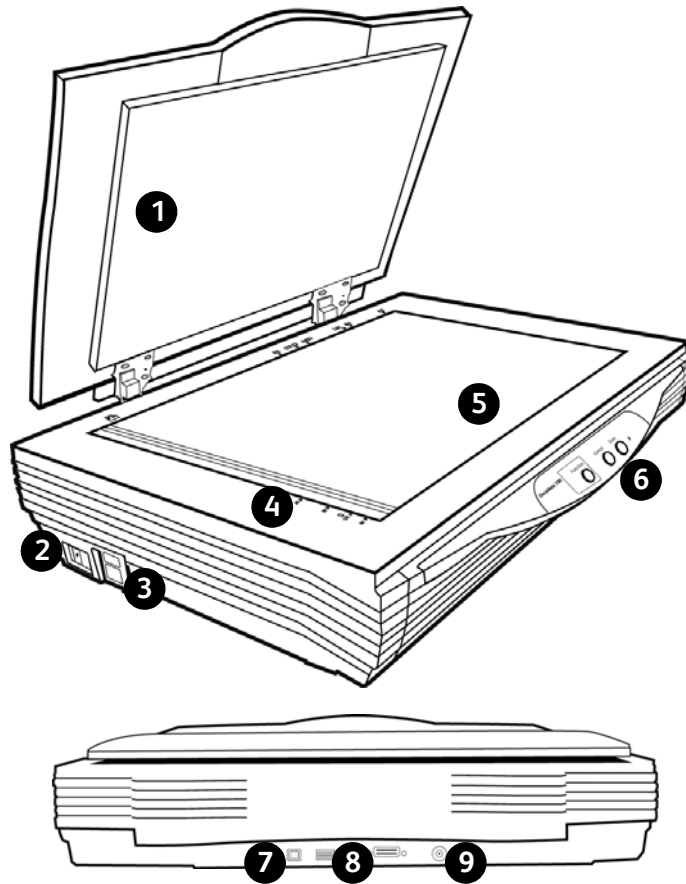

①

Document  
Pad

②

Power  
Switch

③

Scanner Lock

④

Reference  
Frame

⑤

Flatbed  
Glass

⑥

Control  
Panel

⑦

Output USB  
Port

⑧

Input USB  
Port

⑨

Power Jack

**Document Pad**—Holds documents in place on the scanner glass.

**Power Switch**—Turns the power on and off.

**Scanner Lock**—Locks or unlocks the scanning head.

**Reference Frame**—Reference marks indicating where to align various paper sizes.

**Flatbed Glass**—Place document face down to scan.



**Control panel**—One Touch scanning controls.

**LED Number**—Shows the current scan setting for the Scan button.

**Function button**—Selects the scan setting for the Scan button. Press to cycle through the settings.

**Cancel button**—Press to cancel the current scan.

**Scan button**—Press to scan a document.

**Status light**—Shows the scanner's status. Refer to the Troubleshooting section for additional details.

**Output Universal Serial Bus (USB) port**—Connects the scanner to the computer.

**Input Universal Serial Bus (USB) port**—Connects another Xerox desktop scanner to the DocuMate 700.

**Power jack**—Connects the power cord to the scanner.

# Installation

# 1

Installation is a quick, three-step process:

1. Install the software
2. Connect the scanner
3. Register the scanner

## **Please make sure of the following before you begin installation:**

- The information in this guide may cover software not provided with the scanner you purchased. Please disregard any information about the software not applicable to your scanner. Visit our web site at [www.xeroxscanners.com](http://www.xeroxscanners.com) for the latest software updates for your Xerox scanner.
- If your computer has AntiVirus or AntiSpyware software running, you may encounter alerts or messages during installation asking you to allow the installation to proceed. Although the messages will differ based on the software your computer is running, in each case you should allow the installation to proceed if that option is available. Alternatively, you can turn off the AntiVirus or AntiSpyware software before installing your scanner, but if you do, make sure to turn it back on again when installation is finished.
- If you already have a scanner connected to your computer, it is recommended that you remove that scanner's driver program prior to installing your Xerox scanner. You can remove these programs from the Windows Add/Remove programs list. Please refer to the user manual provided with your other scanner hardware for instructions about removing the driver and software for that unit.
- If your computer is running Windows Vista, you may see the Vista User Account Control screen asking you to confirm system changes. Click the Continue button to allow the installation to proceed.

# Step 1: Install the Software

The installation disc contains the necessary driver, and scanning software, to use your DocuMate 700.

## To install the software:

1. Start Microsoft Windows and make sure that no other applications are running.
2. Insert the installation disc into your computer's DVD-ROM drive.  
The disc automatically starts.



3. The Select Language window opens. Click the drop-down menu arrow and select the language to use. Click **OK**.
4. The disc's Main Menu window opens.

**NOTE:** If the disc does not start, check the following:

- Make sure the disc drive's door is completely shut.
- Make sure the disc was inserted in the drive in the proper direction (label side up).

To launch the disc manually:

- Open the Windows options for your computer's disc drives.
- Double-click the icon for your DVD-ROM drive.
- The Installation menu for the disc should now open.

If the menu does not open:

- From the list of files on the disc, double-click the file named START32.EXE.

**NOTE:** The Scanner Readme file has late-breaking news about your scanner. The readme file is in HTML format and will open in any standard browser.

- On the Main Menu, select **Install Products**.



- Make sure the boxes for **Nuance PaperPort®** and **Scanner Driver** are checked.



**NOTE:** The software provided with your scanner may differ slightly from the list shown in the window.

- Click **Install Now**.

**The PaperPort Installation begins:**

- The Select Language window opens. Click the drop-down menu arrow and select the language to use. Click **OK**.
- On the PaperPort Welcome window, click **Next**.  
Installing PaperPort will uninstall any existing version of PaperPort and will install the newer version. Your existing PaperPort files will not be affected.

3. Read the PaperPort license agreement and select **I accept the terms in this agreement**, then click on **Next**. If you choose not to accept the license agreement, the installation will terminate and the PaperPort software will not be installed.
4. On the Customer Information window, accept the current values or enter new information, then click **Next**.
5. On the Setup Type window, keep the default Setup Type and click **Next**.
6. Click **Install** to begin the installation.
7. On the Product Registration window, do one of the following:
  - Select **Register online**, click **OK**, then follow the registration instructions.
  - Select **Print registration form**, click **OK**, then follow the instructions to complete and print the registration form.
  - Select **Remind me in 7 days** and click **OK**.
8. At the InstallShield Wizard Completed window, click **Finish**.

#### The scanner driver installation will now start

1. The Welcome to the One Touch 4.0 Setup Wizard opens.



2. Click **Next**.
3. On the Xerox License Agreement window, read the license agreement. If you accept the terms, select **I Agree** then click **Next**.  
If you choose not to accept the license agreement, the installation will terminate and the scanner driver will not be installed.

4. The next window lists the choices of the drivers that you can install for your scanner.

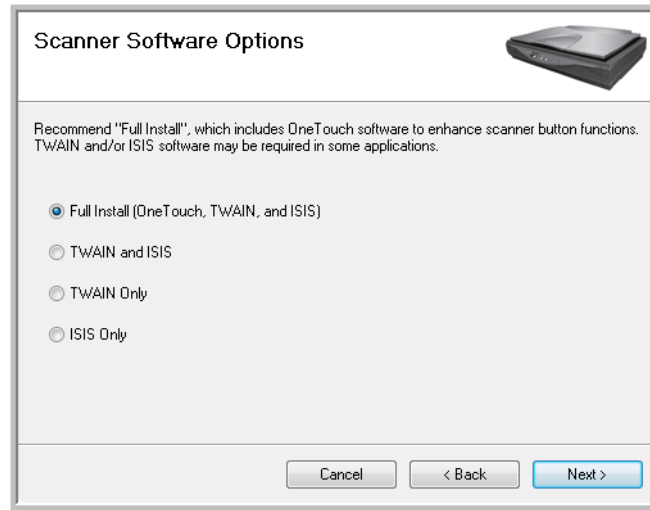

5. Select the option that you want then click on **Next**.
- **Full Install (OneTouch, TWAIN and ISIS)**—This is the recommended installation. It installs the One Touch 4.0 software, which provides the necessary driver software for the scanner buttons to work. It also installs the TWAIN and ISIS drivers for scanning from within TWAIN and ISIS scanning applications.
  - **TWAIN and ISIS**—The TWAIN and ISIS drivers are installed and you can scan from within TWAIN and ISIS scanning applications. You will not be able to use the buttons on the scanner.
  - **TWAIN Only**—The TWAIN driver is installed and you can scan from TWAIN scanning applications only. You will not be able to use the buttons on the scanner.
  - **ISIS Only**—The ISIS driver is installed and you can scan from ISIS scanning applications only. You will not be able to use the buttons on the scanner.
6. A window opens with image quality samples asking you to select an image for your Color Space setting. Select the option that looks best to you and click **Next**.

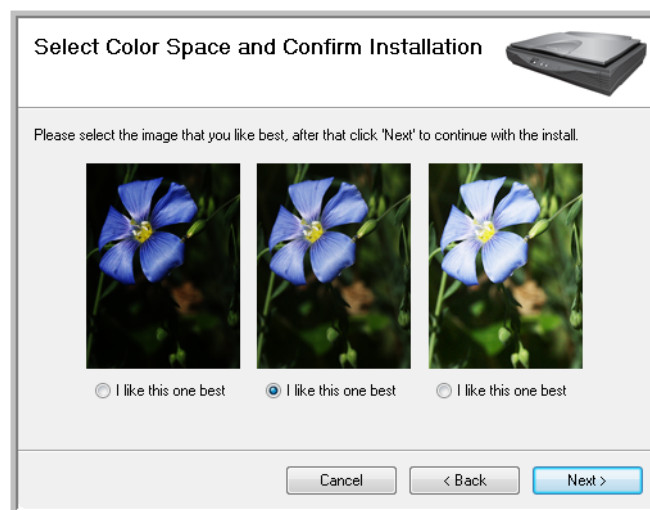

7. **STOP** when you see the “Complete the installation by connecting your hardware” window. Do **NOT** click **OK** yet. Leave the window open and proceed to the next section.

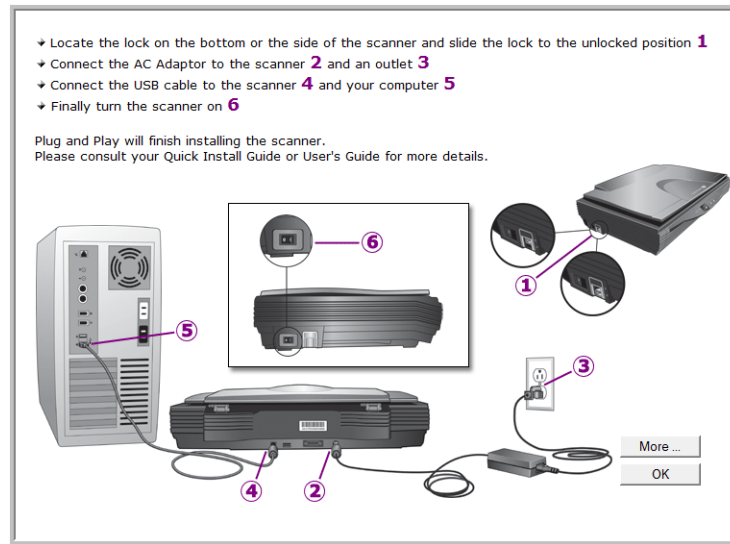

**NOTE:** If you do not see this on-screen diagram for connecting the scanner, stop and follow the instructions below.

## Step 2: Connect the Scanner

1. Remove any tape from the top and side of the scanner.



2. Slide the locking tab, on the side of the scanner, to its unlocked position. The scanner will not scan when locked.

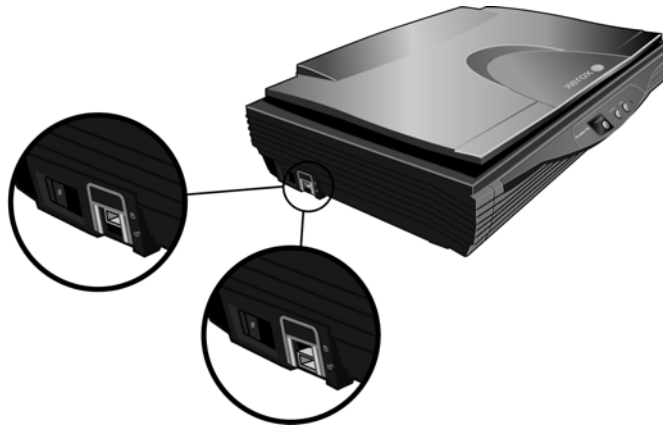

3. Plug the power supply into the power port on the scanner.

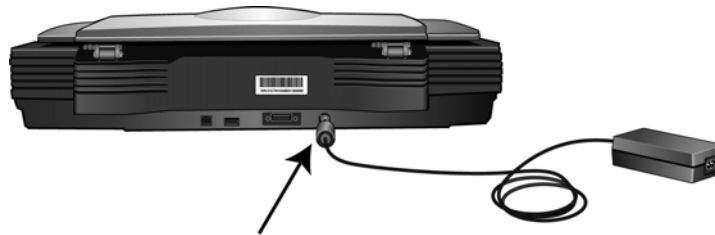

**NOTE:** Only use the power supply (HEG42-240200-7L made by HiTron) included with your scanner. Connecting any other type of power supply may damage your scanner, and will void its warranty.



4. Plug the power cord into the power supply and into a wall outlet.

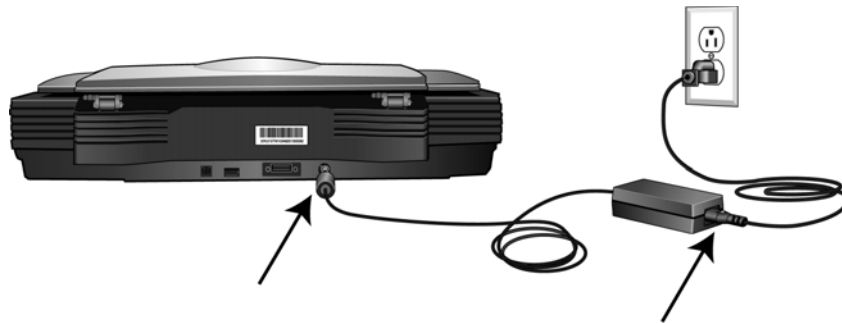

5. Remove any tape from the USB cable.
6. Plug the flat end of the USB cable into an available USB port on the back of the computer.
7. Plug the square end of the USB cable into the output USB port on the back of the scanner.



If the plug does not attach easily, make sure that you are plugging it in correctly. Do not force the plug into either connection.

- Turn on the power switch, located on the side of the scanner.



The status light comes on and flashes indicating that the scanner is receiving power.

Your computer recognizes that a scanner has been plugged into the USB port and automatically loads the appropriate software to run the scanner.

If your computer is running Windows XP or Windows Vista, you will see a message similar to the one below.

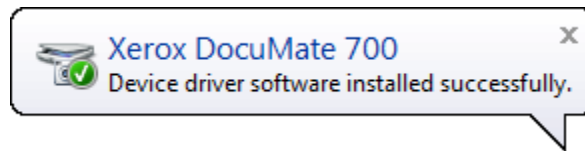

9. When you're certain that the software has completely loaded, return to the "Complete the installation by connecting your hardware" window.

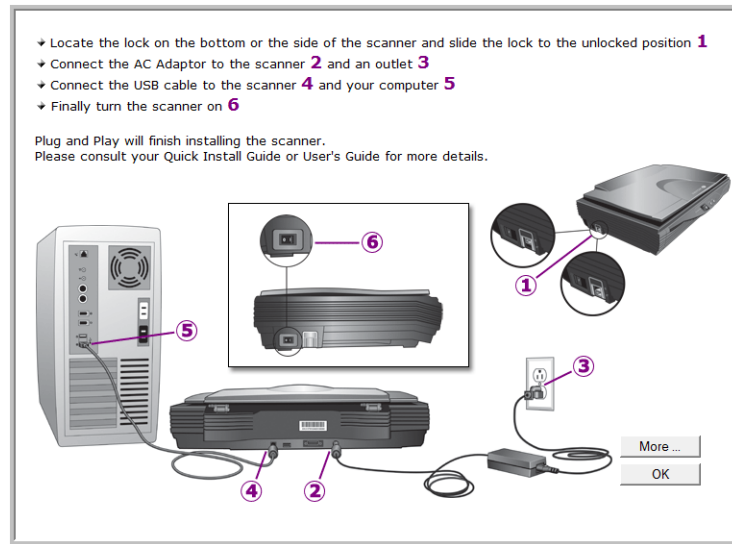

To see a quick overview about accessing and navigating the One Touch Button Panel, click **More**. When you're finished reading the additional information, click **OK**.

10. Click **OK** to complete the installation process.
11. Click **Close** on the Installation Complete window to close and exit the software installer.

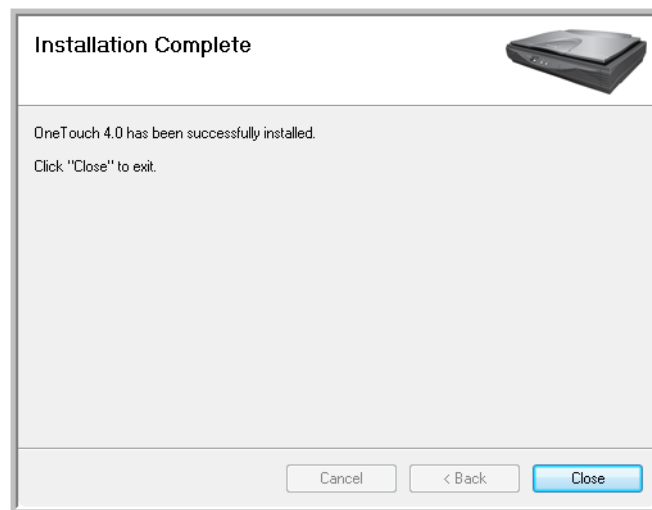

## Step 3: Register Your Scanner

Registering your scanner is important as it provides you with access to our free telephone support service. Registration also gives you free access to software updates for your scanner.

### To register your scanner:

You will need an active internet connection to register your scanner. If you do not have internet access you can contact our customer service department to register the scanner. Please refer to the Technical Support Card, that you received with the scanner, for our customer service contact information.

1. Open an Internet Explorer window, or any other internet browser you have installed on your computer.
2. In the web address field type [www.xeroxscanners.com](http://www.xeroxscanners.com).
3. Press Enter on your computer's keyboard or click the option on screen to go to the web address.
4. When the Xerox scanners web page loads click on Register Your Product.
5. Fill in the registration form, all required fields have an asterisk (\*).

**NOTE:** A valid email address is required for registration.

6. You will be asked to enter the serial number for the scanner, it is located on the back of the scanner.



The Serial Number

7. After filling in the form, click on **Submit Your Registration** to complete the registration.

# Additional Applications Available with Your Scanner

Your scanner includes free, additional applications as described in the following table.

1. Return to the disc's Main Menu and click **Install Products**.
2. Select the additional applications you want to install, then click **Install Now**.



3. Follow the instructions on the screen to install each of the additional products.

Software	About the Software
Adobe® Reader®	Adobe Reader is a stand-alone application that you use to open, view, search, and print PDF files. This application is located on the disc in the User Guides section.
Nuance OmniPage® Pro	OmniPage Pro provides precision OCR analysis, advanced layout detection, and Logical Form Recognition™ (LFR) technology. Advanced security features quickly turn office documents and forms into over 30 different PC applications for editing, searching and sharing. Custom workflows handle large volumes of documents, and you can use its tools to print to PDF.
EMC QuickScan™	QuickScan is a stand-alone, out-of-the-box imaging solution that provides all the necessary capabilities for high-speed scanning, image enhancement, viewing, annotation, printing and storing images. It uses an ISIS-certified driver for scanning and includes flexible job separation and barcode recognition. The Demo version lets you try the application first.

You can now view and save the User Guides.

# View the User Guides

1. On the Main Menu, click **User Guides**.



The User Guides are in Adobe® PDF format. If you need to, click **Install Adobe Reader** to install it now. Follow the instructions on the installation windows.

If your computer already has Adobe Reader installed, please do not select it unless the version provided on the installation DVD is a newer version than the one currently installed on your computer.

2. Click on **View scanner documentation** to access the scanner user guide and other documentation related to using the scanner's One Touch features.

Click on **View software documentation** to access the user guides for the software applications provided with the scanner. For instance, the Nuance PaperPort user guide is in this section.

From either of these user guide windows, click on the **User guides menu** button to return to the main user guide window, then select the other documentation section to view the user guides.

Scanner documentation window

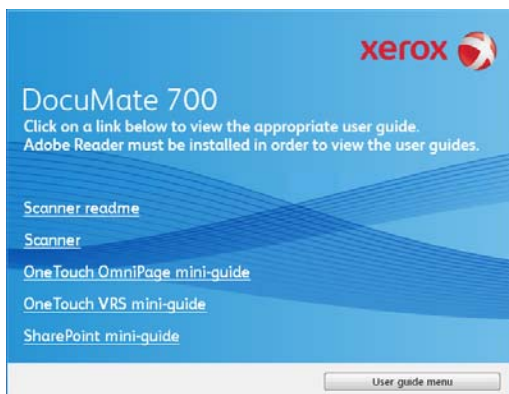

Software documentation window

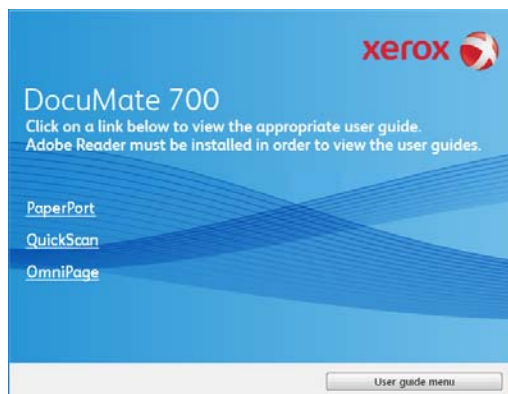

3. Click the name of a User Guide you want to view and it will open in Adobe Reader. Use the Adobe **Save** command to save that User Guide on your computer.

The **SharePoint Mini-Guide** has information about a feature in the One Touch software to link to Microsoft's SharePoint application. This brief Mini-Guide explains how to setup the SharePoint link in One Touch.

The **One Touch VRS Mini-Guide** has information about a feature in the One Touch software to use VRS when scanning. This brief Mini-Guide explains what the feature is and how to use the VRS settings when creating or modifying a scan configuration.

The **One Touch OmniPage Mini-Guide** has information about the OmniPage module in the One Touch software. This brief Mini-Guide explains what the feature is and how to use the OmniPage settings when creating or modifying scan configurations.

4. When you're finished, click **Main Menu** to return to the Main Menu window and click **Exit**.
5. Remove the installation disc and store it in a safe place.

That's it! Installation is finished and your DocuMate 700 is ready to scan.

## Scanning Interfaces

If you selected the recommended installation options (see page 5), then you have several different options to scan with your Xerox DocuMate 700 scanner. Each method scans equally well, so use the one with appropriate options for the item you are scanning.

- **One Touch**—When you press the Scan button, the item on the scanner glass is scanned using the scan settings indicated by the LED number. The scanned image is then sent to a software application or location on your computer. You can also scan using the on-screen One Touch button interface. The One Touch software is where you configure the settings for the **Scan** button. See "Scanning From One Touch" on page 15.
- **TWAIN Interface**—This option uses your scanner's TWAIN interface to scan. Select scanning options before scanning, put the document in the scanner, then click the Scan button in the TWAIN interface window. See "Scanning from TWAIN" on page 53.
- **Windows Image Acquisition (WIA)**—This option uses the Microsoft Windows set of choices for scanning. Select the WIA scan settings, put the document in the scanner, then click the Scan button in the WIA window. See "Scanning from WIA" on page 73.
- **ISIS Interface**—This option uses the ISIS interface for scanning. Select the ISIS scan settings, put the document in the scanner, then click the Preview Scan button in the ISIS window. See "Scanning from ISIS" on page 77.

# Scanning From One Touch

# 2

The scanner has 9 One Touch scanning functions. When you press the **Scan** button on the scanner, the scanner starts scanning using the settings for the current LED number. The One Touch button panel shows the 9 scanning functions on screen. The panel button names, such as PDF, eMail or Fax, indicate the original factory settings for the Destination Application assigned to a button.

Press the **Function** button to cycle through the 9 One Touch scanning options

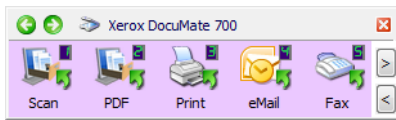
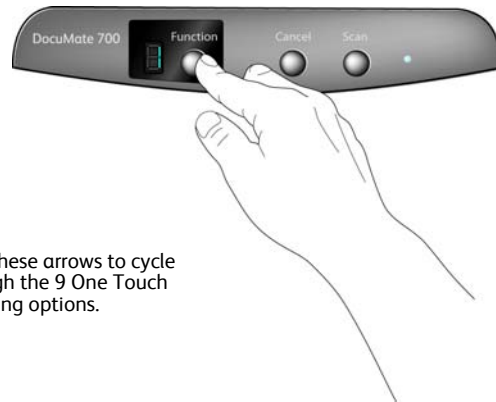

Click these arrows to cycle through the 9 One Touch scanning options.

**NOTE:** Always remove any staples or paper clips from documents before placing them on the glass to avoid scratching it.





## Default One Touch Settings

One Touch is your main scanning interface for using the scanner. Based on the recommended installation of PaperPort and the scanner driver, your scanner is pre-configured to scan items for various basic tasks, such as email or fax, then send the scanned image to a Destination Application.

You can change any of these settings. Please see “Configuring the One Touch Buttons” on page 20 for instructions.

For example, the eMail button is set up to scan documents then immediately attach them to a new eMail message in your default eMail program. The email application will default to the email program specified in the internet options of Internet Explorer.



A folder icon for a button means that the button is set up to archive the scanned item. The scanner sends the scanned image directly to a folder without opening the image first in a Destination Application.



A question mark for a button means your computer does not have the appropriate software or hardware for the initial factory settings. In that case, you would probably want to change the name and Destination Application to something else.



If PaperPort, OmniPage or One Touch OmniPage is not installed, then the options for sending to word processing applications such as Microsoft Word will not be available.



**NOTE:** The default page size in each configuration is based on your computer’s Windows setup of United States or Metric Units.

- If United States is the selected measurement, the default page size in each profile will be based on the United States standard page sizes such as 8.5” x 11”.
- If Metric is the selected measurement, the default page size in each profile is based on the ISO 216 standard and the majority of the profiles will default to A4.

## Scan using the One Touch button

Pressing the **Scan** button scans the item and sends the image to the Destination Application associated with the selected function LED number.

1. Place an item *face down* on the glass. Align the top edge of the item with the reference marks on the scanner, then close the scanner lid.

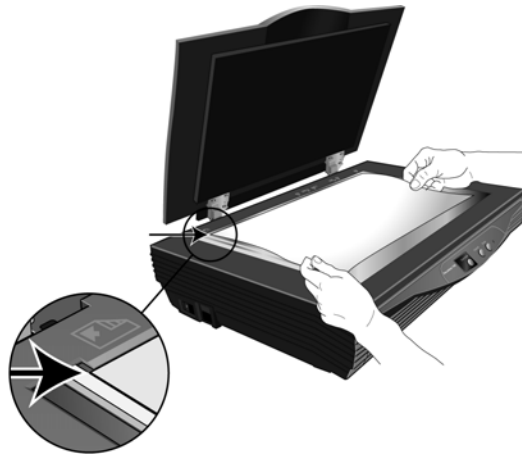

2. Press the function button to select the scan setting you want.
3. Press the **Scan** button.

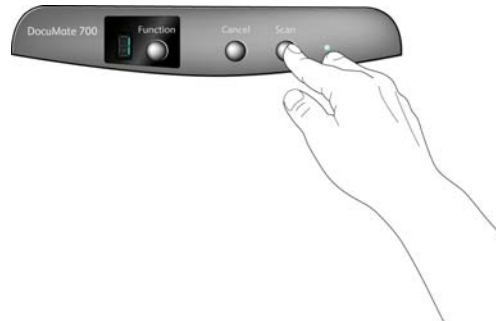

4. A scan progress window opens and the image is sent to the selected application for the Scan button. In this example the Destination Application is the PaperPort desktop.

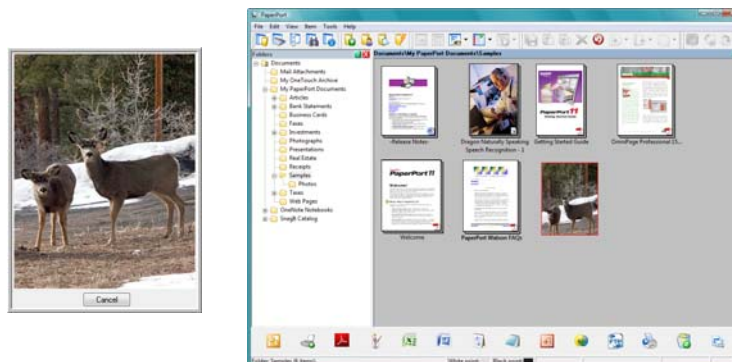

## Scan from the One Touch Button Panel

Scanning from the button panel on your computer's screen works like pressing a button on the scanner. The scanner scans the item, then sends the image to the Destination Application indicated by the button's icon.

### To scan from the One Touch Button panel:

1. Place an item *face down* on the glass. Align the top edge of the item with the reference marks on the scanner, then close the scanner lid.
2. Click on the One Touch icon in the Windows notification area (at the lower right corner of the screen.)

One Touch Icon



3. The One Touch Button Panel opens and shows the first five on-screen scanning buttons.

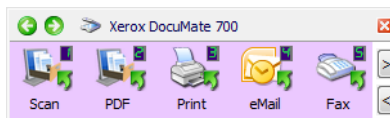

4. Click the button you want to use to scan.
5. A scan progress window opens and the image is sent to the selected application for the One Touch button.

In this example the Destination Application is the PaperPort desktop.

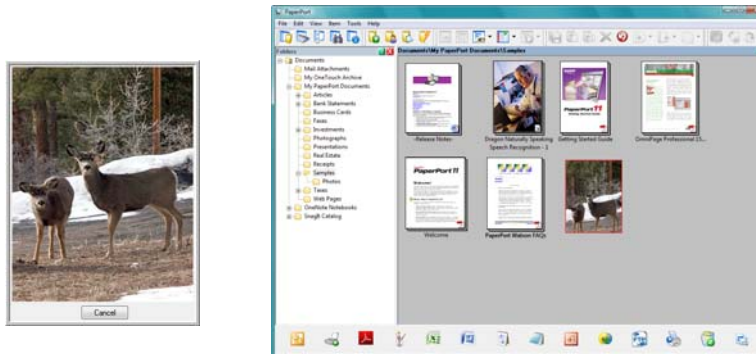

6. You can now work with the image in the Destination Application.

## Features of the One Touch Button Panel

The One Touch panel is your on-screen set of controls for the scanner. From the panel you can access the hardware settings for your scanner and configure the Scan button.

Click on the One Touch icon to open the panel.

The Button View

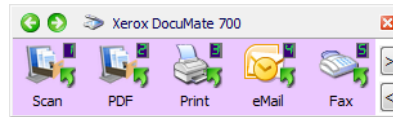

The Hardware View

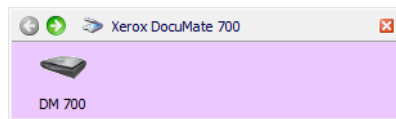

The Detail View

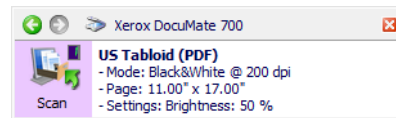

### The Title Bar

- Green arrows—click to cycle through the panel's 3 views.
- Scanner icon—click to open the scanner's hardware properties.
- Red "X"—click to close the One Touch panel.

### The Button View

- *Left-click* on a Destination Application icon to start scanning.
- *Right-click* on a Destination Application icon to open the One Touch Properties.

### The Detail View

- *Left-click* on a Destination Application icon to start scanning.
- *Right-click* on a Destination Application icon to open the One Touch Properties.
- *Single-click* on the detailed information to open the One Touch Properties.

### The Hardware View

- *Left-click* on the scanner icon to return to the Button view.
- *Right-click* on the scanner icon to open the scanner's hardware properties.

# Configuring the One Touch Buttons

When you installed the scanner, the software configured each One Touch button with appropriate settings consisting of: a **Destination Application**, a **Scan Configuration**, and a **File Format**.

1. Click on the One Touch icon.
2. Right-click a button on the One Touch Button Panel.
3. The One Touch Properties window opens.

One Touch Icon

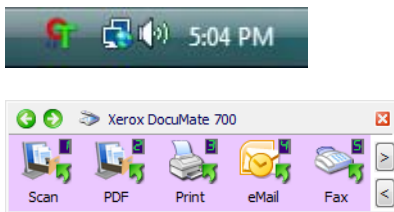

Right-click on a button (for example, button 2) and the Properties window opens for that button.

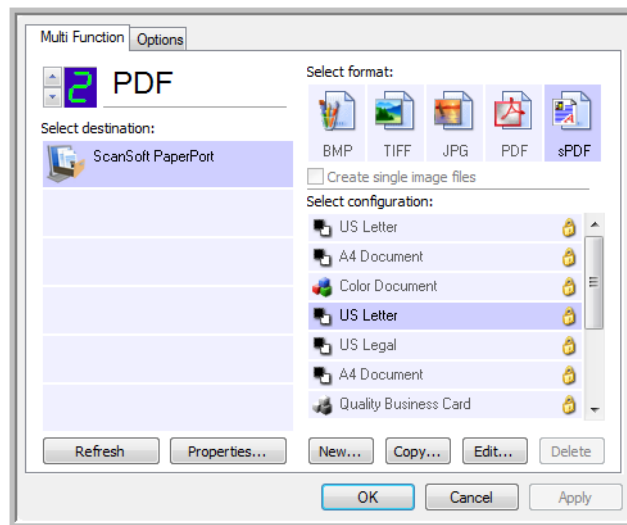

**NOTE:** Some of the options on the One Touch Properties Window are “grayed out” and are not available, these options are not appropriate for your scanner model.

## Changing a Button setting:

1. Click on an application name in the **Select Destination** list.
2. Select a file format in the **Select Format** panel.
3. Select a scanning configuration in the **Select Configuration** list.
4. Click on **OK** to save the changes.
5. Place a page in the scanner.
6. Click on the button that you made the changes for.
7. The scanner starts scanning and sends the image to the application, with the file format and scanning configuration you specified.

**NOTE:** The next section contains detailed information on making changes to the One Touch Properties window.

## Selecting New Settings

Click the Options tab to select options.

Select the Destination Application that will open when you are finished scanning. You use the destination application to view and work with your scanned images.

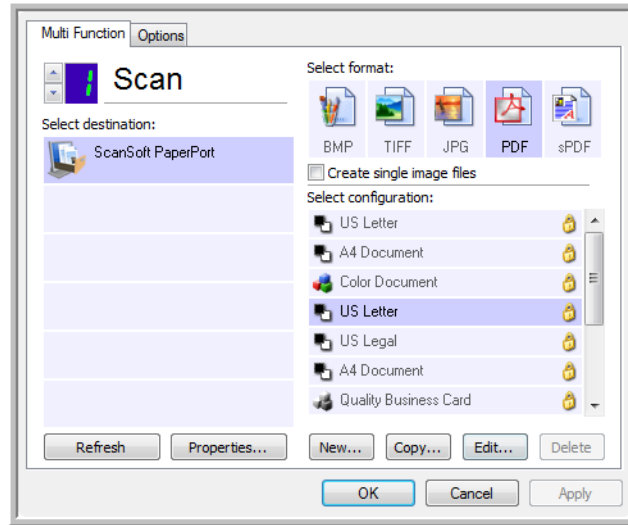

Select a file format for your scanned images.

Select a configuration for scanning the item.

The settings on the One Touch Properties window are:

**Select Destination**—The list of Destination Applications that One Touch can send a scanned image to so that this application opens immediately after scanning is complete.

Select the application you want One Touch to send the scanned image to.

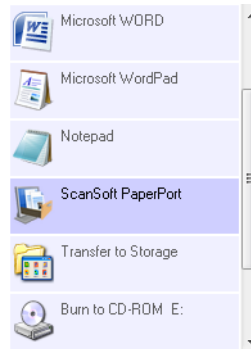

**NOTE:** If you select a word processing program such as Microsoft WordPad or Microsoft Word that can be used for OCR (such as TXT or RTF), the text in scanned images is automatically converted to word processing text.

**Select Configuration**—The list of available scan configurations for the selected button. The configuration's basic settings include: scanning mode, resolution (dpi), page size, brightness (Br), and contrast (Cr). To see a selected scan configuration's settings, click its icon. Click the icon again to close the detailed information.

Click the icon of a selected configuration to view its settings.



These icons next to each scan configuration indicate the scanning mode.



See the sections “Creating a New Scan Configuration” on page 23 and “Editing or Deleting Scan Configurations” on page 29.

**NOTE:** Use Configure Before Scan if you want to set the scanning mode manually before scanning. See “Configure Before Scan” on page 29.

**Select Format**—A set of file formats for the scanned image for the selected button. The formats are based on the type of Destination Application you select. This example shows the formats that apply to Microsoft Outlook.



The icon names indicate their file types. See “Selecting Document and File Format Options” on page 32 for more information about the available formats.

**Options tab**—Displays a window for selecting options related to the selected Destination Application for the scanned image. See “Selecting Options for One Touch” on page 36 for instructions on configuring the list of available destinations.

**Properties button**—Displays a window for selecting properties for each type of Destination Application. See “Setting Destination Application Properties” on page 37.

**Refresh button**—Updates the links between all your computer’s Destination Applications and One Touch 4.0. If you install new software that can be used as a Destination Application, click the **Refresh** button to link the new software to One Touch 4.0

**New/Copy/Edit/Delete buttons**—Click **New** or **Copy** to add new scan configurations to the list. Click **Edit** or **Delete** to change or remove them.

**OK/Cancel/Apply buttons**—**OK** accepts any changes and closes the window. **Apply** accepts any changes but leaves the window open so you can continue making additional changes.

**Cancel** closes the window without accepting any changes.

## Creating a New Scan Configuration

The scan configurations are where you select the scanning resolution, brightness, mode (color, black&white, or grayscale), and a number of other settings.

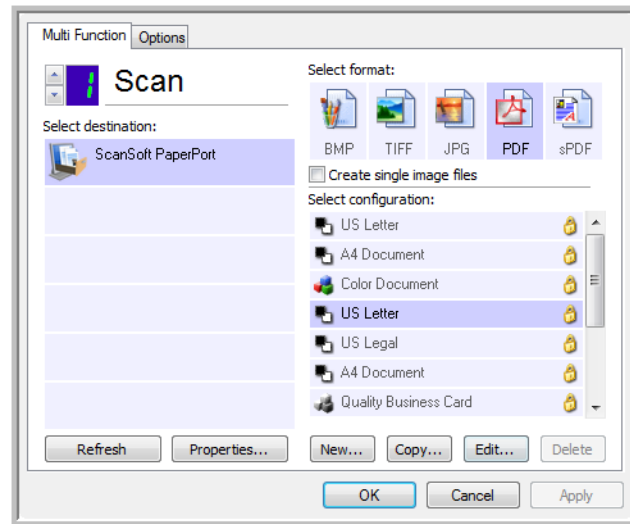

### To create a new configuration:

1. Scroll through the applications in the Select Destination list and click the application you want for the new scan configuration.
2. Click the **New** button.

If you want to start from the settings of another configuration, select the configuration, then click the **Copy** button.

The Scan Configuration Properties dialog box opens.

### The Scan Settings Tab

1. On the Scan Configuration Properties dialog box, type a name.

Type a new name for the configuration.

Select the scan mode and drag the slider to set the resolution.

Drag the sliders to set the Brightness and Contrast.

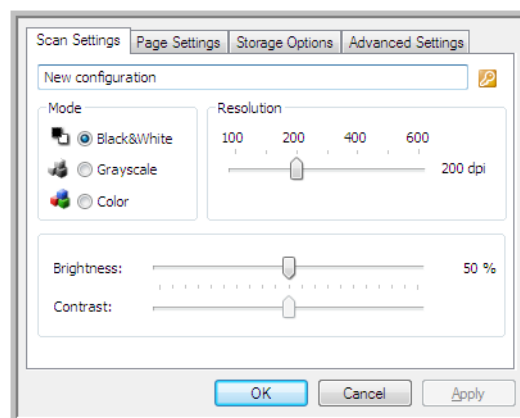

If the configuration is locked, click the lock to unlock it. The icon becomes a key.

2. Select scan settings for the new scan configuration.  
**Mode**—Select a scanning mode:



- **Black&White** to scan in black and white. For example, letters and memos are usually scanned in black and white.
- **Grayscale** to scan items such as documents containing drawings or black and white photographs.
- **Color** to scan color photographs and other color items. Color scans have the largest file size.

**Resolution**—Drag the slider to the right or left to adjust the dots per inch (dpi) of the resolution. The higher the dpi setting, the sharper and clearer the scanned image. However, higher dpi settings take longer to scan and produce larger files for the scanned images.

**Brightness** and **Contrast**—Drag the sliders to the right or left to adjust the brightness and contrast of the scanned image. The Contrast setting does not apply to the Black&White mode.

Brightness refers to the lightness or darkness of the image. Contrast is the range between the darkest and lightest portions of the image. The greater the contrast, the more difference between the lighter and darker shades in the image.

3. If you want to lock the configuration, click the key icon to change it from a Key to a Lock.
4. Click **OK** if you are done making changes for this configuration.

## The Page Settings tab

Click the **Page Settings** tab to select options applicable to how you want the image to appear after scanning.

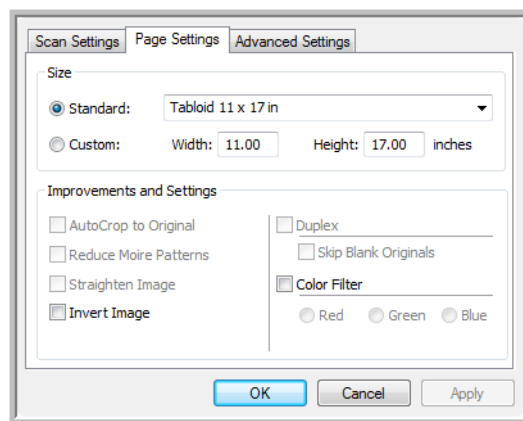

Click the name to toggle between inches and millimeters.

**Size**—Click **Standard**, click the menu arrow and choose a page size from the list, or click **Custom** and enter the horizontal and vertical page dimensions in the boxes. The maximum size is 11.8" x 17". The units of measurement can be inches or millimeters. Click the name of the units, inches or millimeters, to toggle between them.

**Improvements and Settings**—Only the options that apply to the selected scanning mode on the Scan Settings tab are available.

- **Reduce Moiré Patterns**—Moiré patterns are wavy, rippled lines that sometimes appear on the scanned images of photographs or illustrations, particularly newspaper and magazine illustrations. Selecting **Reduce Moiré Patterns** will limit or eliminate moiré patterns in the scanned image. This option is only available at lower resolutions.

- **Invert Image**—Only available for Black&White Mode, this option reverses the black and whites of an image.

Original Image



Inverted Image



- **Color Filter**—Color filter is the ability of your scanner to automatically remove a color from a scanned image. For example, if you are scanning a letter with a red watermark, you can choose to filter out the red so the scanned letter just shows the text and not the red watermark. Color filter applies to Black & White or Grayscale scanning modes.

The original with a red watermark over black text.

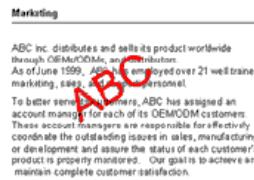

The scanned item with the red filtered out.

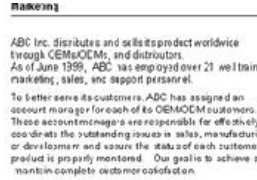

If you are finished making changes to the configuration, click on **OK** to save the settings and close the window.

### The Advanced Settings tab

1. Click the **Advanced Settings** tab.  
The options of the Advanced Settings tab are for the Color or Grayscale scanning mode.

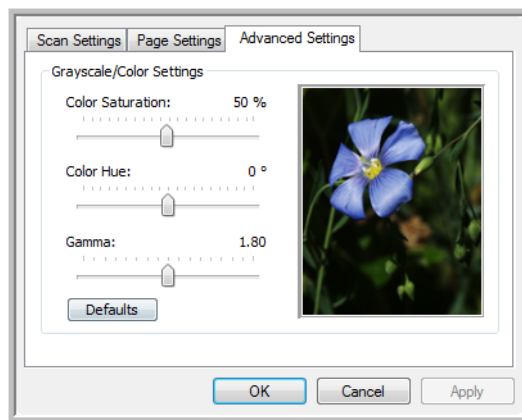

2. Drag the sliders to the left and right to change the color settings. As you do, the image changes to show the effects of the new settings.

**Saturation**—the strength or purity of a color.

**Hue**—the color your eyes see as reflected from the image

**Gamma**—is the tone curve and the starting point for image enhancement. As you raise or lower the Gamma value, the values at which Color Saturation, Color Hue, Brightness and Contrast affect the image are changed. It is recommended that you keep the default Gamma value or adjust this setting before adjusting the other options.

3. Click **OK** to save the new configuration.

It will now be in the list of Scan Configurations on the One Touch Properties window for the appropriate Destination Applications.

## The Device Settings Tab

A Device Settings tab is on the Scan Configurations dialog box when your selected Destination Application sends the scanned image to a printer, fax application, or other device. You use the options on the Device Settings tab to select settings for the device.

1. Click on the **Device Settings** tab.

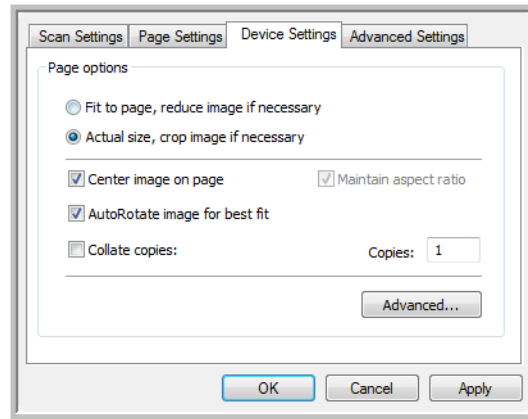

**Fit to page, reduce image if necessary**—If the scanned image is too big to be printed or faxed on a single page, the image will automatically be reduced to fit the page.

**Actual size, crop image if necessary**—If the scanned image is too big to be printed or faxed on a single page, the image will automatically be cropped around its edges to fit on the page.

**Center image on page**—The image will be printed in the center of the page instead of at the top left corner.

**Maintain aspect ratio**—The aspect ratio is the length-to-width relationship of the image's dimensions. Select this option so the image's relative proportions remain constant.

**AutoRotate image for best fit**—If the image is a Landscape format and the device is printing in the Portrait mode, or vice versa, rotate the image to fit on the page.

**Collate copies**—If you are printing more than one page, collate the copies. Enter the number of copies in the **Copies** box.

**Advanced**—Click to see additional settings for the device. The dialog box that opens is specific to the device. For example, if the device is your printer, the dialog box is your printer's setup settings.

2. Click **OK** or **Apply**.

## The Storage Options Tab (Archive)

A Storage Options tab is on the Scan Configurations dialog box when the Destination Application is Transfer to Storage. You use the options on this tab to select where to save your scanned items for storage when scanning with that particular Scan Configuration.

1. Click on the **Storage Options** tab.

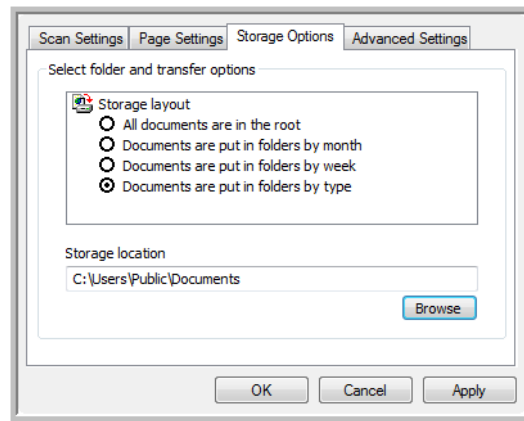

2. Click the Storage Layout options you want.  
**All documents are in the root**—The scanned documents are saved in the root of the folder specified in the Storage Location.  
**Documents are put into folders by month, week, or type**—Folders are created based on your selection (month, week, or file type) and the scanned documents are saved in those folders. New folders are created for each month and week so you can keep track of when you scanned the documents.
3. If you want to store your archive documents in some other location, click the **Browse** button to specify the new location.
4. Click **OK** or **Apply**.

## Editing or Deleting Scan Configurations

Editing and deleting is normally for the configurations you create, not for your scanner's pre-set configurations.

**NOTE:** Your scanner comes with a number of configurations pre-set at the factory. To ensure that your scanner will always have a set of correct scan configurations, do not delete the pre-set configurations. We also recommend that you keep those configurations locked so they are not inadvertently deleted. That way, you will always have the factory-settings available. If you do delete or edit them, and want to get the factory pre-sets back again, you will need to uninstall then re-install your scanner.

### To edit or delete a scan configuration:

1. Open the One Touch Properties window.
2. Select the scan configuration you want to edit or delete.

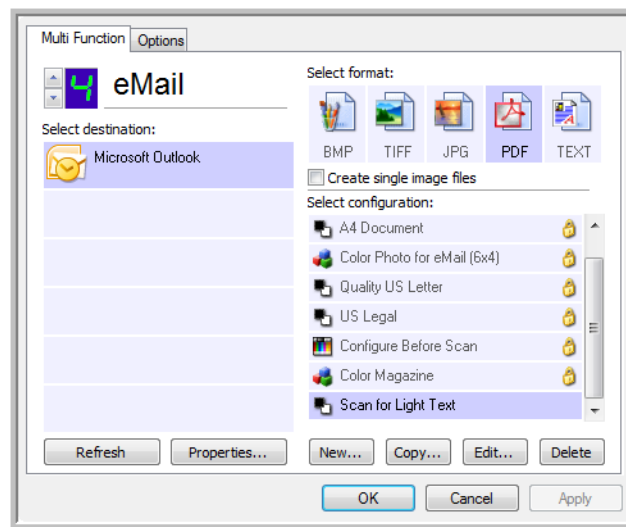

Select the scan configuration to edit or delete. It must be unlocked, as indicated by not having a lock displayed here.

- To delete the configuration, click the **Delete** button.
  - To edit the configuration, click the **Edit** button.  
Edit the settings and click **OK**.
3. Click **OK** to close the One Touch Properties window.

## Configure Before Scan

You can set up the scanner so that, when you press a button or click it on the Button Panel, a different scanning interface opens before the scanning starts. To set up the scanner for this capability, you select Configure Before Scan from the scan configuration list.

Choosing Configure Before Scan simply opens either the TWAIN or WIA scanning interface when you press a button. You can then use the interface to change the Resolution, Scan Mode, and other settings. When you scan, the scanned image will still be sent as the file type and to the same Destination Application already selected in the One Touch Properties window for that button.

The option Configure Before Scan can be used when you want to scan multiple pages and have them appear in one file.

### To set Configure Before Scan:

1. Open the One Touch Properties window.
2. Select the scan configuration **Configure Before Scan**.

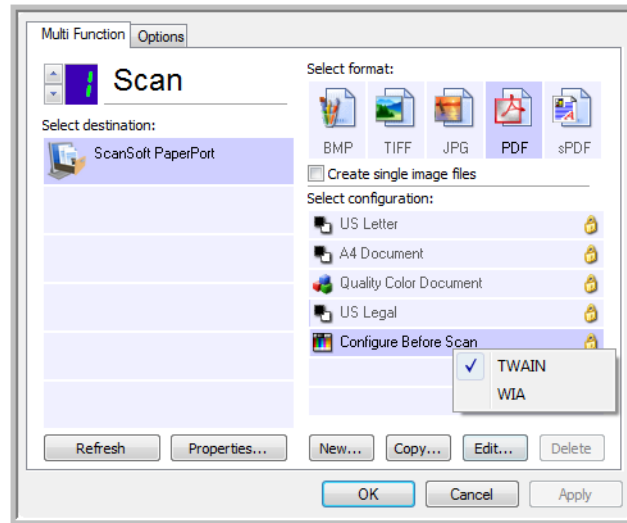

Select then right-click on **Configure Before Scan** to get the menu, and choose the interface to use for scanning.

3. Right-click on **Configure Before Scan** and choose an interface to use for configuring before scanning.

**TWAIN**—The TWAIN Interface opens for you to make changes prior to scanning. See “Scanning from TWAIN” on page 53.

**WIA**—The Windows Image Acquisition (WIA) Interface opens for you to make changes prior to scanning. See “Scanning from WIA” on page 73.

4. Click **OK** or **Apply** on the One Touch Properties window.

### To Scan Using Configure Before Scan

1. Put the document or photo on the flatbed glass and close the lid.
2. Click the button you set up to use Configure Before Scan.
3. The TWAIN Interface opens.
4. Choose your scan settings, such as the Picture Type of Color, Grayscale or Black & White, Resolution in DPI, and Page Size.
5. Click the **Scan** button on the TWAIN Interface.

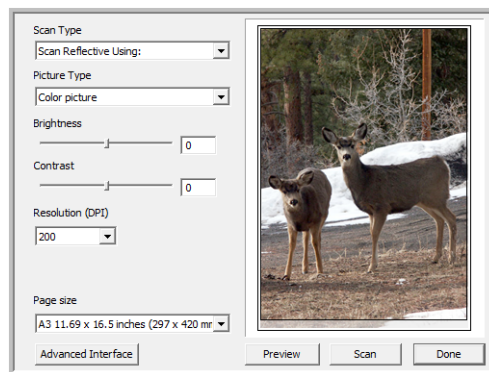

- The item is scanned. When finished, click the **Done** button and the image will be sent to the Destination Application specified in the One Touch 4.0 Properties window.  
In the example shown on the previous page, the Destination Application is PaperPort.

## To Scan Multiple Pages

You can use Configure Before Scan to create multi-page documents from individually scanned pages.

**NOTE:** Using the Configure Before Scan option to scan multiple pages does not apply for page formats BMP and JPG. Please make sure the page format on the One Touch 4.0 Properties window is set to TIFF, PDF, or one of the Text formats. Make sure the option **Create single image files** is not selected. Please see [page 32 for instructions on changing the file settings](#).

- Put the page on the Flatbed Glass and close the lid.
- Click the button you set up to use Configure Before Scan.
- When the TWAIN Interface opens, select the appropriate scan settings for your document.
- Click the **Scan** button on the TWAIN Interface.
- After the Scanning Progress bar closes, place the next page on the Flatbed Glass, close the lid, and click the Scan button again.
- Continue until you have scanned all the pages in your multi-page document.
- When you're finished scanning, click the **Done** button on the TWAIN Interface.
- All the scanned pages will be sent to the Destination Application set in the One Touch 4.0 Properties window. If the Destination Application is PaperPort, the pages will be grouped as a single stack of pages.

## Canceling a Configure Before Scan

- Click **Cancel** in the scanning progress window.

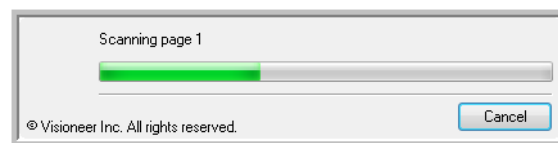

- The following window will open asking if you want to cancel the entire job.

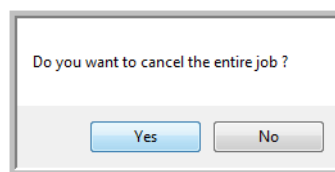

- Yes**—Scanning stops and all pages scanned in this batch, up to this point, will be deleted. The TWAIN interface will close and you can restart your scan from the beginning.  
Choose **Yes** if the TWAIN scan settings are incorrect for your current scanning batch. For instance, the Picture Type is Black & White but you want to scan your documents in color. Choose **Yes** to delete any scanned pages, then start over but select the correct picture type before scanning.



- No**—Scanning stops, but all pages scanned in this batch, up to this point, are not deleted and the TWAIN interface remains open. You can place a new page in the scanner, adjust the TWAIN settings for it, then click the **Scan** button in the TWAIN interface to continue scanning. At the end of the scanning batch, all pages from the first portion of the scan and second will be sent to the Destination Application.

Choose this option if, for instance, you have been scanning a Black & White document but you want to insert a color page into it. Instead of having to re-scan the entire batch, you can stop the current scan, change the picture type from Black & White to Color, then restart the scanning without losing the pages already scanned.

## Selecting Document and File Format Options

The format option you select determines the file format of the scanned document. Appropriate format options and file types are available for the type of Destination Application selected for the button.

The available options are for images and text.

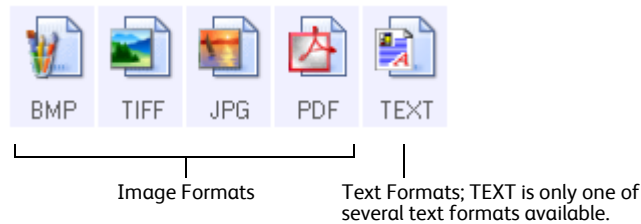

The Text Formats are for text file types. The names of the formats indicate their file types. See “Text Formats” on page 33 for details.

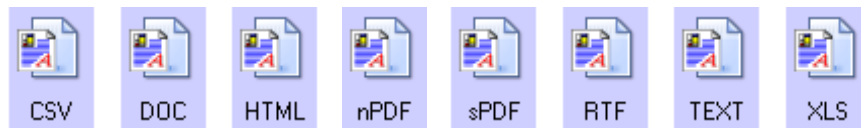

### Create Single Image Files

The TIFF and PDF formats support multiple page documents. If you are scanning as a TIFF or PDF file and want one file created for each image scanned, select **Create single image files**. Note that this option is automatically selected and disabled if you have selected a format that only supports single pages, such as BMP or JPG.

This option can be used in conjunction with Configure Before Scan to send multiple single-page files to a destination when scanning from within the TWAIN interface.

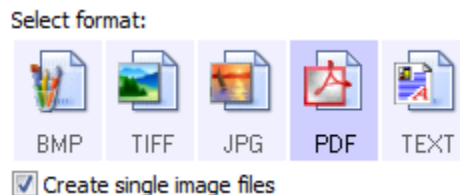

## Image Formats

Select an image file format for photos, artwork or other documents that you want to save as images. BMP and TIFF are standard image file formats generally used if you want to do additional image processing, such as photo touch-up or color correction. Both of those file formats tend to be larger than the JPG format.

Because JPG image files can be reduced in size, the JPG format is often used for images on web pages, or if file size might be a problem when electronically sending the files. JPG files are reduced in size by lowering their image quality, and you can select the degree of quality for your scanned images from the JPG file format icon.

The PDF format is often used to create images of text pages. You may want to select PDF as the format when scanning text pages that do not require OCR processing or other processing. The PDF format is also used to put multi-page documents on web sites as pdf-readable files. As with the JPG option, the PDF format can be reduced in size or quality.

### To select a JPEG or PDF file size:

1. Select **JPG** or **PDF** as the page format.
2. Right-click on the **JPG** or **PDF** icon.  
A menu opens.

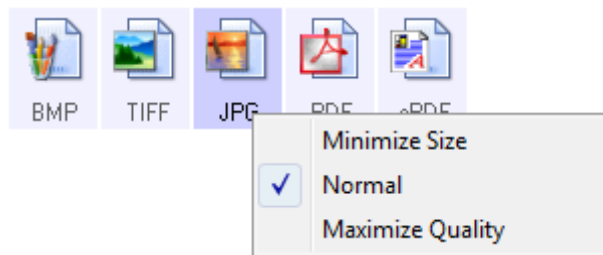

3. Choose the file size/image quality option for your scanned images.

**Minimize Size**—Smallest file size, lowest image quality.

**Normal**—Medium file size, some loss of image quality.

**Maximize Quality**—Largest file size, no loss of image quality.

Your selection pertains only to the button currently selected on the One Touch Properties window. Other buttons that have JPG or PDF selected as the Page Format are not affected, so you can set the JPG or PDF file size/image quality independently for each button.

4. Click **OK** or **Apply** on the One Touch Properties window.

## Text Formats

Selecting the text format option also selects OCR processing as an automatic step for scanning. Therefore, when you scan a document with the text format selected, the text portions of the document are automatically converted to editable text.

Select a text format for documents with text or numbers, such as a business letter, report, or spreadsheet. The text format icon has several file formats available, depending on the Destination Application you select.

The specific file format is the file name extension on the text format icon.

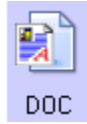

The specific text format; this example is for Microsoft Word.

As you select Destination Applications that are text applications, the text format icon changes to match the file type of the application. In some cases, the Destination Application supports several file types, and you can right-click on the icon to choose the particular file type for that application.

**To select a file type for the text format:**

1. Select the Destination Application.
2. Right-click on the text format icon.

The menu options depend on the type of Destination Application you select.

Example menu for the Text format when the selected application is Microsoft's Word.

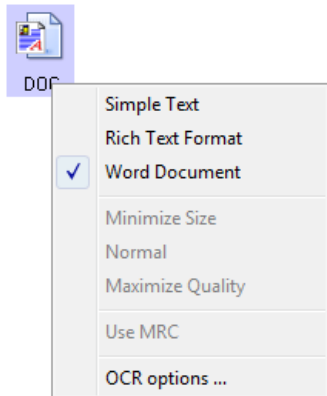

Example menu for the Text format when the selected application is Transfer to Storage.

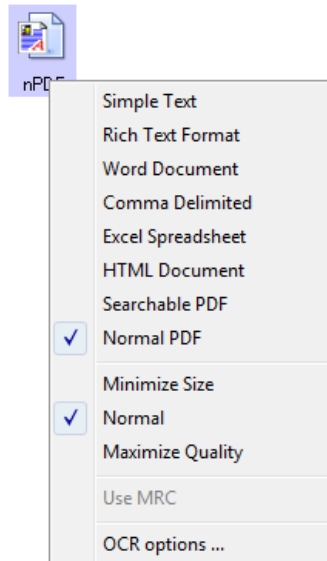

3. Choose the file type that you want for the text format.

**Simple Text**—The .txt file format. Text with no formatting; used by the standard Microsoft Notepad application.



**Rich Text Format**—The .rtf file format. Text that retains formatting when converted. Available with Microsoft Wordpad and Word.



**Word Document**—The .doc file format used by Microsoft Word.



**Comma Delimited**—The .csv file format; used for database or spreadsheet data with fields, when the document is converted into editable text the fields are maintained.



**Excel Spreadsheet**—The .xls file format used by Microsoft Excel.



**HTML Document**—The .htm file format used to create web pages.



**Searchable PDF**—The .pdf file format used by Adobe Acrobat. This format converts scanned text into PDF with an invisible text layer for searching.



**Normal PDF**—The .pdf file format used by Adobe Acrobat. This format converts scanned text into a PDF with the text ready for editing in a PDF editing program.



4. Click **OK** or **Apply** on the One Touch Properties window.

Detailed information about these text file formats, and instructions for setting up the OCR options, are in the One Touch OmniPage Mini-Guide located on the installation disc in the User Guides section.

## Selecting Options for One Touch

The One Touch Options determine the types of Destination Applications available for scanning, as well as additional options for scanning.

### To select options:

1. Open the One Touch Properties window and click the **Options** tab.

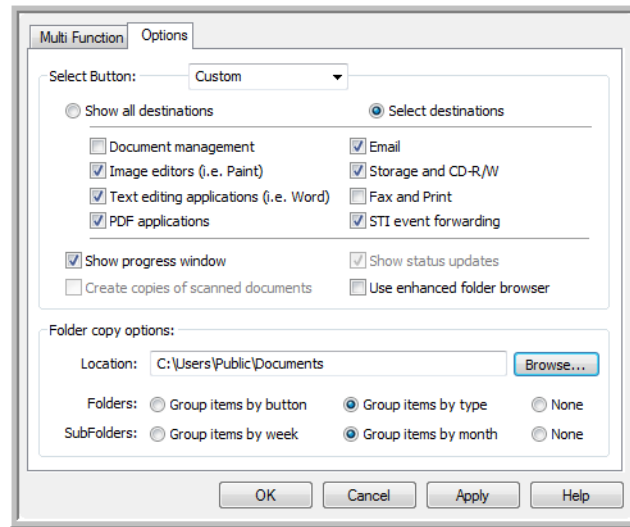

2. Select options as described below.

**Show All Destinations**—This option selects all the Destination Application categories. The list of Destination Applications available for the selected button will include all the applications on your computer that fall into these categories.

**Select Destinations**—Select this option to individually choose the types of applications to include in the list of Destination Applications. Check the boxes for the type of application to include.

- **Document Management** includes PaperPort and other applications for processing and keeping track of your scanned documents.
- **Image Editors** include Microsoft Paint and other drawing and graphics applications.
- **Text Editors** include Microsoft Word and WordPad, Microsoft Excel, and other word processing and spreadsheet applications. Select this option if you want OCR processing to convert your scanned documents to text that you can edit.
- **PDF applications** are for documents scanned to PDF format.
- **Email** includes Microsoft Outlook and other email applications.
- **Storage and CD-R/W** is for either storing scanned documents in a folder, or sending them to a CD burner to create a CD containing the scanned documents.
- **Fax and Print** is for sending your scanned documents directly to your printer or fax software for faxing.
- **Sti event forwarding** is for using another application's interface for scanning. The One Touch Event Forwarding dialog box opens so you can select which application to use to continue scanning.

3. Click **Apply**, then click on the Multi Function tab to see the new settings.

## Global Options

- **Show Progress Window**—Select this option to display the progress window of the document(s) during scanning.
- **Use enhanced folder browser**—Select this option if you want to save your scans to a network location that is not a mapped drive on your computer.
- **Create copies of scanned documents**—Sometimes the image of a scanned document is only saved as a temporary file until its Destination Application is finished using it. In those cases you may want an additional, permanent copy saved on your hard drive. The copies will be saved in the folder specified in the **Folder Copy Options** section.

This option is not available if either **Document Management** or **Storage and CD-R/W** are selected, because, by default, file copies for those types of Destination Applications are already automatically saved in the folder for copies.

- **Folder Copy Options**—This section of the dialog box sets the location for copies of your scanned documents and how you want to group them.

Click the **Browse** button and select the folder for saving the copies. Select the grouping option for the documents. The Group by button option groups the documents under the name of the One Touch button. Group by type arranges the scanned documents by the type of file, such as .rtf or .jpg. If you also want to group them by date you can choose the week and month options.

## Setting Destination Application Properties

The different types of Destination Applications have various properties that you can select.

1. On the One Touch Properties window, click a Destination Application.
2. Click the **Properties** button.

Click a Destination Application.

Click the Properties button

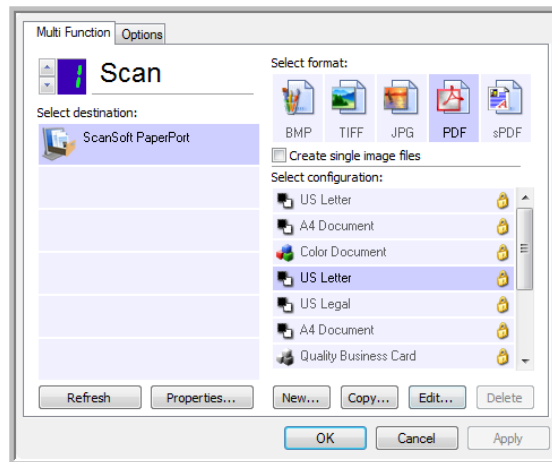

A One Touch 4.0 Link Properties dialog box opens for the type of Destination Application you selected, and the available options are for that type of application.

## PaperPort Properties

These properties apply to PaperPort, and are for designating the folder to receive your scanned items.

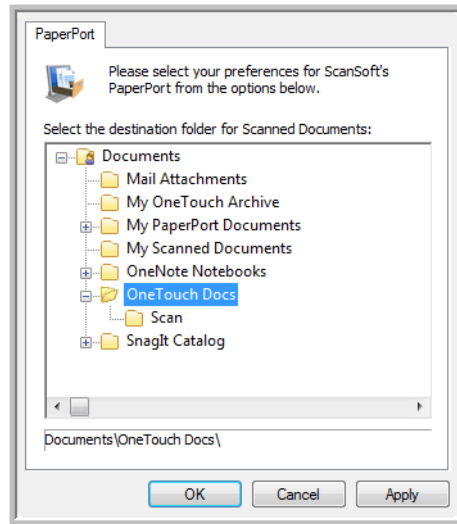

1. Select the PaperPort folder where you want the file of the scanned image to be located.
2. Click **OK**.

## Text Documents Properties

These properties apply to Microsoft Word, Microsoft Excel®, and the other applications indicated by their icons in the list. The properties apply to the Optical Character Recognition (OCR) settings for the applications.

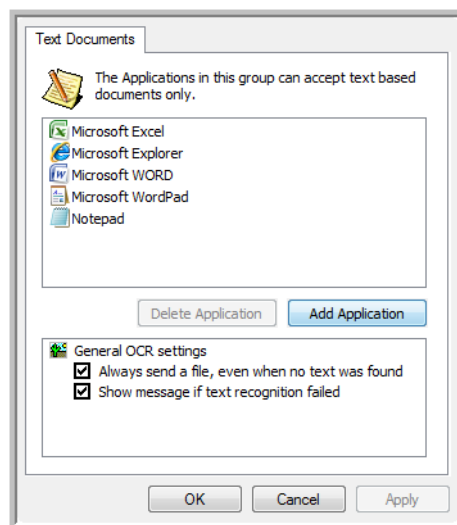

1. Click in the OCR settings boxes for the options you want.

The options will apply to all the applications in the group.

**Always send a file, even when no text was found**—The scanned file is sent to the OCR reader even if the image does not appear to contain text. This could occur if you scanned a photograph with a scanner button set for text applications.

**Show message if text recognition failed**—A message will open on the screen if the OCR reader does not detect text in the image.

2. To add another application to the list, click the **Add Application** button. The Add Text Based Link dialog box opens.

Here you can define a custom application that can accept a text document.

Step 1: Select the path to the application

Step 2: Name the application

Step 3: Select an icon for this application

Step 4: Select the text formats supported by this application

- HTML Formatted file (\*.HTML)
- Rich Text Format (\*.RTF)
- Standard ASCII text file (\*.TXT)
- Alpha PDF format (\*.PDF)

Cancel Add

3. Click **Browse** to find the application you want to add to the list.  
When you select the application using the Browse button, steps 1 and 2 on the dialog box are automatically filled in, and the application icon appears in step 3.
4. Select the icon in Step 3 of the dialog box. That is the icon that will appear in the One Touch Destination List.
5. In step 4 of the dialog box, select the file formats that the application will accept.  
Refer to the documentation you received with the application to see which text formats the application accepts.  
The options you select at step 4 determine the page format icons in the One Touch Properties window for that group of applications.
6. Click the **Add** button.
7. Click **OK** on the Link Properties window.
8. Click **Refresh** on the One Touch Properties window and the new application should now be available.

Please refer to the One Touch OmniPage Mini-Guide, on the installation disc, for instructions on scanning with OCR.



## Image Documents Properties

These properties apply to Microsoft Paint and other image processing applications.

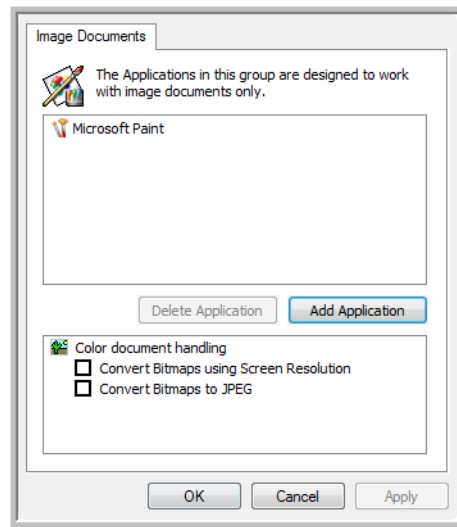

1. Click in the Color document handling settings boxes for the options you want. These options will apply to all the applications in the group.

**Convert Bitmaps using Screen Resolution**—Use this option to ensure that an image will fit on the computer's screen. When a computer screen is set to a lower resolution, bitmap images with a higher resolution may be too big to fit on the screen. Converting the bitmap image to match the screen resolution ensures that the image fits on the screen.

**Convert Bitmaps to JPEG**—JPEG files can be compressed to produce smaller file sizes and, therefore, shorter transmission times. Use this option to provide that compression capability to image files.

2. To add another application to the list, click the **Add Application** button. See the steps on page 39 to add an application to the list.
3. Click **OK**.

## Storage Properties

These properties apply to the Destination Application named Transfer to Storage. If a CD burner is attached to your computer, and your computer is running Windows XP or Windows Vista, you also use this dialog box to start the Burn to CD process. See the section “Scan and Burn to a CD” on page 44.

You can also set up multiple configurations to store scanned items in separate locations. See “Transferring Scanned Documents to Storage” on page 47.

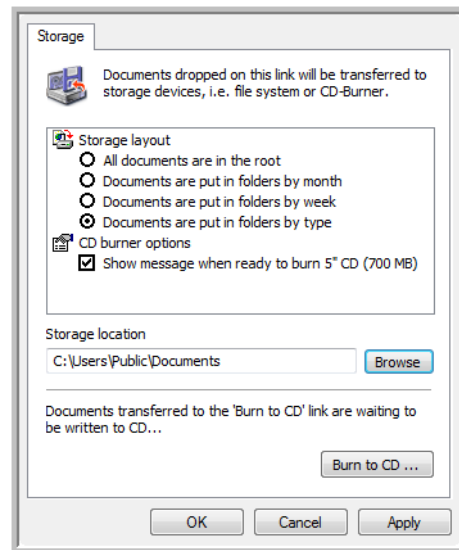

1. Click the Storage Layout options you want.
  - All documents are in the root**—The scanned documents are saved in the root of the folder specified in the Storage Location.
  - Documents are put into folders by month, week, or type**—Folders are created based on your selection (month, week, or type) and the scanned documents are saved in those folders. New folders are created for each month and week so you can keep track of when you scanned the documents.
2. Click the **Browse** button to specify the location to store the scanned documents.
3. If you have a CD burner attached to your computer, the option **Show message when ready to burn 5" CD (700MB)**, should also be selected so you will see a message when it's time to click the **Burn to CD** button.
4. Click **OK** on the Link Properties window.

## eMail Properties

These properties apply to email applications so you can specify the folder for documents that you will attach to an email message. Microsoft Outlook® will accept direct attachment of documents to a blank email message as soon as scanning is finished, but other email applications may not. If you're using one of those applications, such as America Online® (AOL), you need to know which folder contains the scanned documents so you can manually attach them to your email messages.

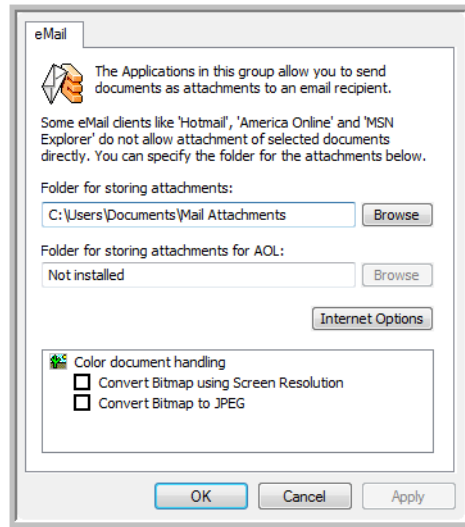

1. Click the **Browse** button for **Folder for storing attachments** and choose a folder for your email attachments.
2. If you are using AOL on your computer, and the folder name for AOL is incorrect, click the **Browse** button and find the correct AOL folder.

Please contact AOL for more information about the folder location in which AOL stores attachments.

3. If you need to change your email client, or any other internet options, click the **Internet Options** button.

The Windows Internet Options Control Panel opens. Click the Programs tab and choose a new email client from the Email list. These are the standard Windows Internet options. Please see your Windows documentation for more information about Internet options. If you are using AOL, please see the AOL user manual for making changes to the Internet options applicable to AOL.

4. Select the options for color document handling.

**Convert Bitmaps using Screen Resolution**—Use this option to ensure that an image will fit on the computer's screen.

**Convert Bitmaps to JPEG**—JPEG files can be compressed to produce smaller files sizes and, therefore, shorter transmission times when you email the file or upload it to the internet.

5. Click **OK**.

# Special Features and Scanning Destinations

The One Touch software has unique scanning options available. You can scan directly to word processing programs, to your computer's CD burner, HTML files and so on.

## Scanning with Optical Character Recognition (OCR)

Optical Character Recognition (OCR) converts text and numbers on a scanned page into editable text and numbers. You can then work with the text and numbers to edit, spell check, change font or type size, sort, calculate, and so forth.

**NOTE:** Xerox recommends that all OCR processing use the original factory settings for OCR scanning that came with your scanner. When scanning with other settings, use at least 300 dpi for the resolution. If the original documents are of poor quality or have a small type font, 400 dpi can be used as the maximum resolution.

The One Touch OmniPage Module or the OmniPage Pro software must be installed on your computer in order to use the OCR options with the One Touch software and your DocuMate 700. The One Touch OmniPage Module was automatically installed when you installed your driver from the installation disc. The One Touch OmniPage Mini-Guide is available on the installation disc. Please refer to that mini-guide for detailed instructions.

### To scan with OCR:

1. Open the One Touch Properties window.
2. Select a text editing program in the Select Destination list, then select a text file format in the Select Format panel.

For example, if you want to edit your document in Microsoft's Word, select that application then choose a file format such as TEXT, RTF or DOC.

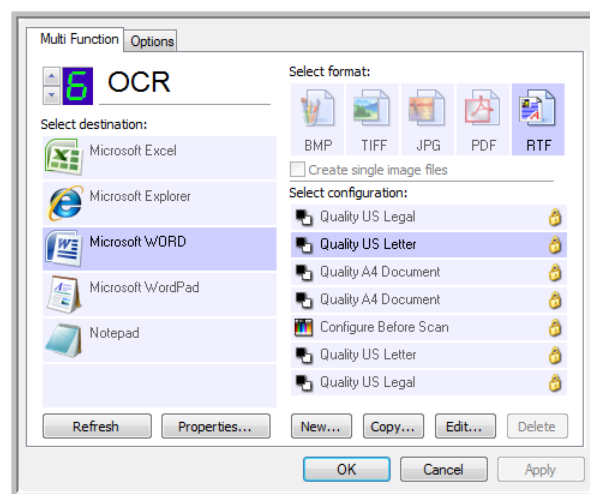

3. Click on **OK** to save the changes and close the One Touch Properties window.

4. Put the document on the flatbed glass and close the lid.
5. Press or click the One Touch button you set to scan with OCR.

Your scanned pages appear in the Destination Application with the text ready for editing and other text processing.

## Scan and Burn to a CD

If you have a CD burner attached to your computer, you can scan directly from your scanner onto a CD. This feature is available only on computers running Windows XP or Windows Vista.

### To scan and burn to a CD:

1. Open the One Touch Properties window.
2. Select **Burn to CD** as the Destination Application.

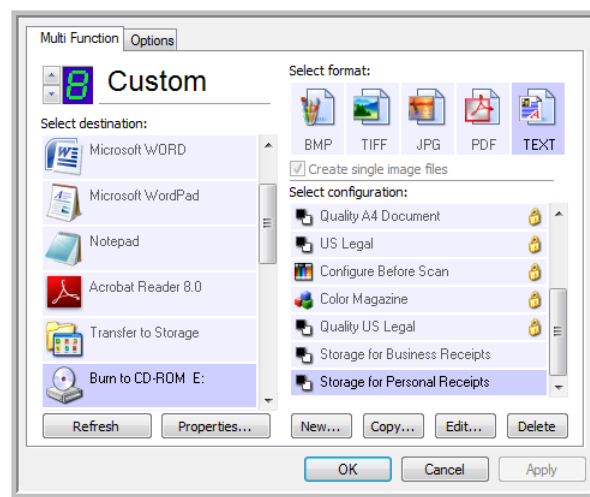

3. Choose a File Format and a Scan Configuration.
4. Click **OK**.
5. Put the document on the flatbed glass and close the lid.
6. Now start scanning using the scanning number you set to scan and burn to a CD.  
The scanner will start scanning. When finished the file will be saved to the Windows location for CD files. An information bubble will appear in the Windows notification area telling you that there are files waiting to be burned to CD.
7. Open the One Touch Properties window, select **Burn to CD** and click the **Properties** button.
8. Make sure a blank CD is in the CD burner.
9. Click the **Burn to CD** button. The CD burner begins and your scanned documents are written to the CD.

If other files are also waiting in this location, they will get written with the One Touch files on the CD.

## Scanning with Event Forwarding (STI)

If you want to specify an application to use for scanning at the start of the process, you can use event forwarding.

### To scan with event forwarding:

1. Open the One Touch Properties window.
2. Select **Still Image Client** as the Destination Application.

You cannot choose a page format for this option because the actual Destination Application is not selected until after you press the scanner button.

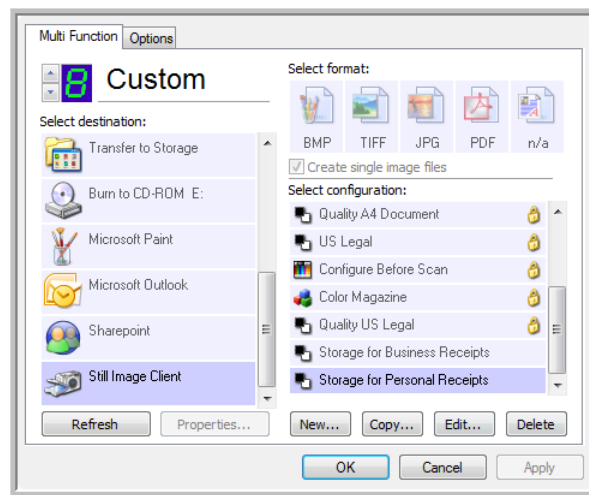

3. Choose a Scan Configuration.
4. Click **OK**.
5. Put the document on the flatbed glass and close the lid.
6. Start scanning using the button you selected for event forwarding.  
A dialog box opens for you to select the application to use for scanning.

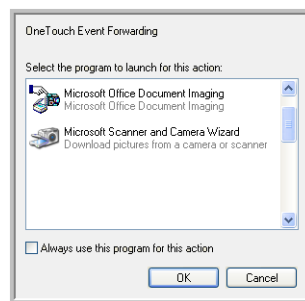

7. Select the application you want in the box and click **OK**.  
Now the application you selected opens and you can continue scanning using the application's interface.

## Creating an HTML Web Page from Your Scanned Documents

You can convert scanned pages to HTML format for posting directly to your web site.

### To scan and create an HTML web page:

1. Open the One Touch Properties window.
2. Select **Microsoft Explorer** as the Destination Application.
3. Choose **HTML** as the Format.

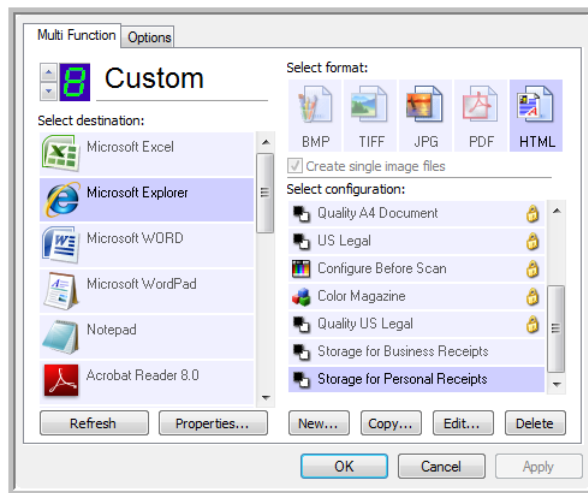

Choose HTML

4. Choose a Scan Configuration that has the settings for the image on the HTML page.
5. Click **OK**.
6. Put the document on the flatbed glass and close the lid.
7. Start scanning using the button you selected for scanning with the HTML format.

When scanning is finished, the document is first converted to editable text using the OCR process, then is converted into an HTML format. Microsoft Internet Explorer then opens showing your converted page.

8. Choose **Save As** from the Internet Explorer **File** menu, give the page a name, and save it in the location you use for your web page files.
9. You can now use Microsoft Internet Explorer or other application to post the document to your web page as you would any other HTML page.

## Transferring Scanned Documents to Storage

With Transfer to Storage scanning, you can scan documents and save them in a folder in one step. The process is ideal for archiving documents without having to manually save or process them. If you choose a text format for the file format, the images are automatically converted by the OCR process into editable text and numbers before being saved.

### To transfer documents to storage:

1. Open the One Touch properties window.
2. Select **Transfer to Storage** as the Destination Application.

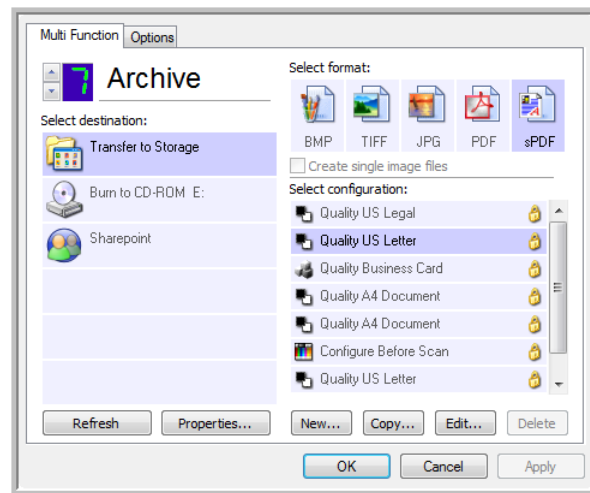

3. Choose a scan configuration and file format for your document.
4. Click **OK**.
5. Now scan the documents using the button you set up with the Destination application as Transfer to Storage.
6. Scanning begins and your scanned pages are stored in the location that you specified on the One Touch 4.0 Link Properties window.

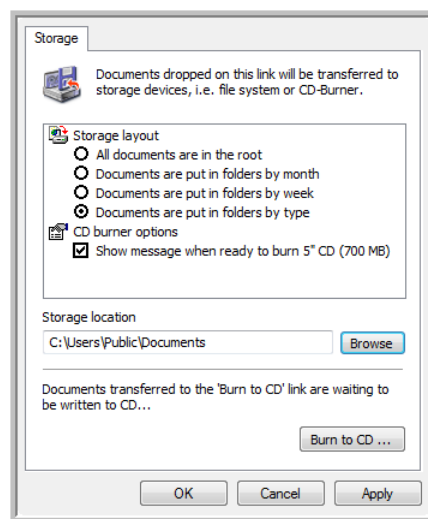

Your scanned documents will be stored at the location you specified on the One Touch 4.0 Link Properties window.



When selecting the storage location for scanned documents, you can select a local folder, or a folder on a server or mapped drive.

## Scanning to Multiple Archive Folders

When archiving documents with Transfer to Storage option, you can scan the documents to different folders. For example, one folder might be for “Business Receipts,” a second folder might be for “Personal Receipts,” and a third folder might be for “Annual Receipts.”

To scan to multiple folders, you create multiple configurations, each with a different storage location for the scanned documents. Scan one set of documents using the scan configuration with the appropriate storage location for that set. Then switch to another scan configuration and scan the next set of documents to store them in their folder.

**NOTE:** The selections you make using the Storage Options tab override the storage location that is set in the Storage Link Properties.

### Setting up multiple folders for transfer to storage:

1. Using Microsoft Windows, create the folders that you want to use for storing scanned items.
2. Open the One Touch Properties window.
3. Select **Transfer to Storage** as the Destination Application.
4. Click the **New** button.

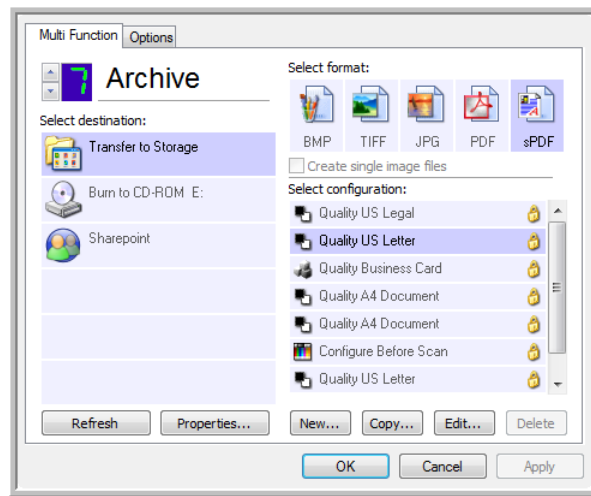

The Scan Configuration Properties dialog box opens.

5. To help you remember which folder it is, give the new configuration a name that indicates the folder name, such as “Business Receipts.”
6. Click the **Scan Settings**, **Page Settings**, and **Advanced Settings** tabs, and select the settings you want.

- Click the **Storage Options** tab.

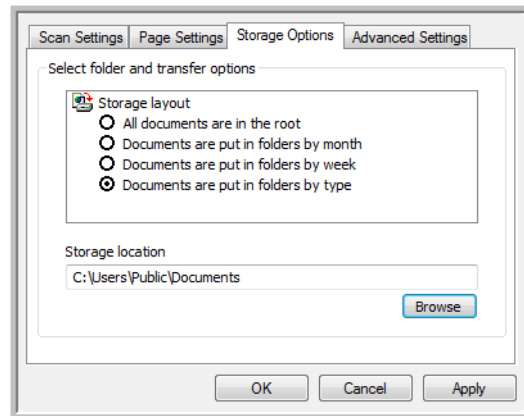

- Click the **Browse** button.
- Select the folder you created for storing the scanned documents.

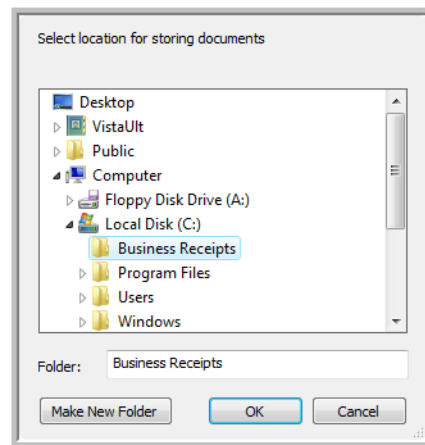

- Click **OK**. The selected folder will now be set as the Storage Location, such as “Business Receipts.”

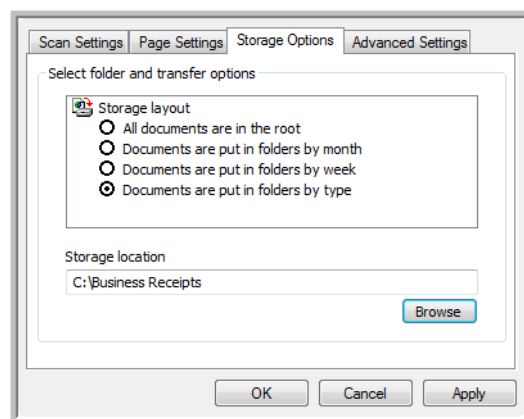

- Click **OK**. The new configuration is now listed as a Transfer to Storage configuration.

- Repeat the process to create additional new configurations, such as one named “Personal Receipts.”

Make sure to designate separate folders as the Storage Locations for the new configurations.

- You will now have multiple configurations set up for the Transfer to Storage destination, and each configuration scans documents to separate folders.

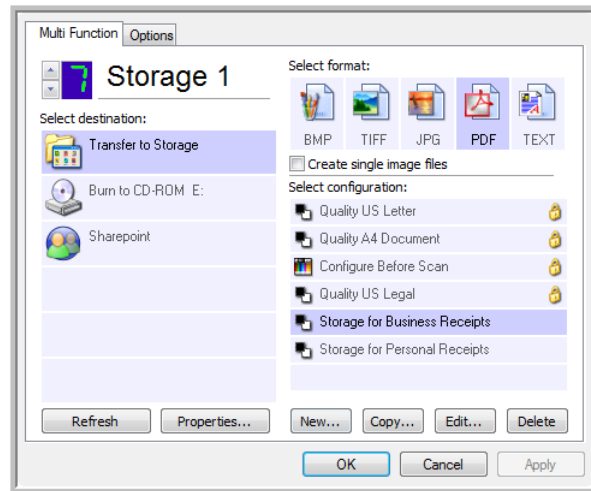

The new configurations apply to the Transfer to Storage Destination Application.

- Now click the arrow buttons to select a scanner button for each new configuration. Click **Apply** to set that button for that configuration.

The following examples show that buttons 7 and 8 have been set to scan to each of the new configurations.

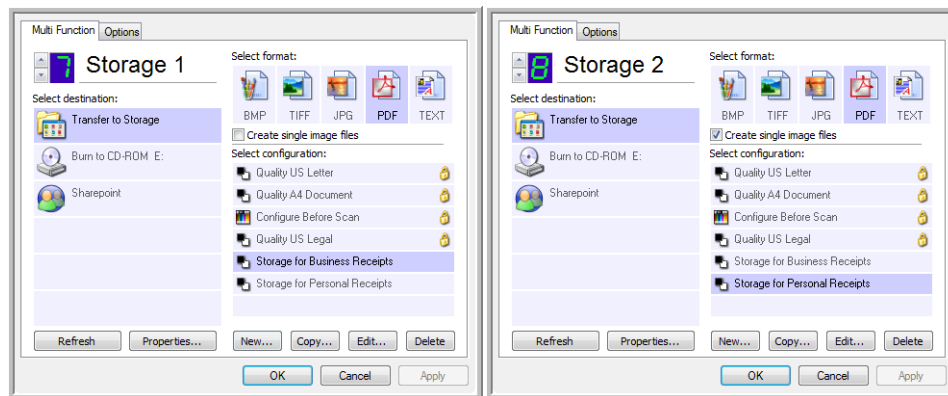

#### Scan to multiple storage folders:

- Insert the document you want to scan to storage.
- Press the Function button on the scanner to get to one of the buttons set up for scanning to storage.
- Press the Scan button to scan the document.
- When scanning is finished, insert the next document and press the Function button to get to the next button you have set up for scanning.
- Press the Scan button to scan the document.

When scanning is finished, the documents are stored in the two separate folders.

# Checking the Hardware and Setting the Lamp Power Saving

1. Right-click on the One Touch icon and choose **Show Hardware** from the pop-up menu.

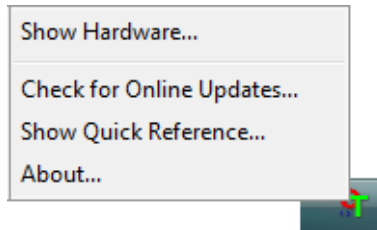

2. The Hardware Properties dialog box opens and shows information about your DocuMate 700.

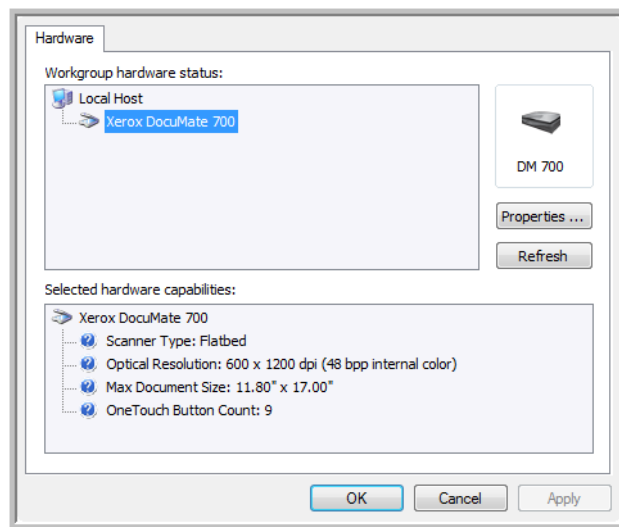

3. Click the **Properties** button.

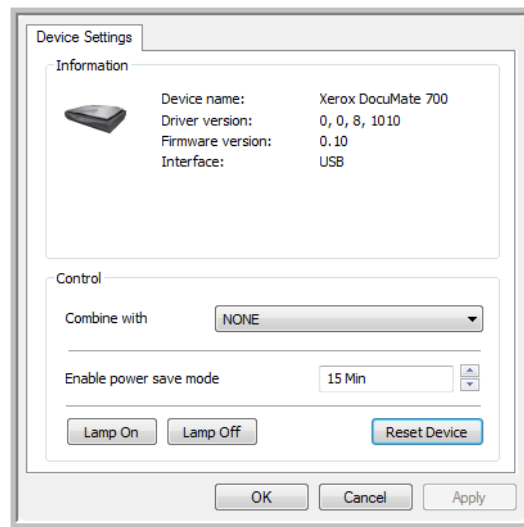

4. Your scanner has a built-in power saving feature that is set to power down after 15 minutes of idle time. You can change the time before the scanner powers down, from 1 minute to a maximum of 3 hours.
5. Click the arrows for the Lamp time-out setting and choose a time setting.  
To turn the lamp on and off manually without turning off power to the scanner, click the Lamp On or Lamp Off buttons.  
To return the scanner to its factory settings, click Reset Device.
6. Click OK to save the changes and close the dialog box.

**NOTE:** The **Combine With** option is for connecting to another Xerox desktop scanner, to add the functionality of that scanner to the DocuMate 700's TWAIN interface. Please see "Connect to Another Scanner" on page 66 for instructions on using this feature.

# Scanning from TWAIN 3

You can scan from any TWAIN scanning application instead of scanning from the One Touch buttons on your scanner or the One Touch button panel.

**A Note About Your Scanner and the TWAIN standard:** TWAIN is a widely recognized standard that computers use to receive images from scanners, digital cameras, and other digital devices. The TWAIN scanning interface can be accessed from any TWAIN scanning application you have installed on the computer. Applications such as Nuance PaperPort and OmniPage, which were provided with your scanner, and many other applications, can use the TWAIN interface for scanning. Because the TWAIN interface is often the same regardless of the software you use to open it, you can still use the instructions in this User's Guide for scanning with your DocuMate 700. To access the TWAIN interface from other software, please refer to their user's guides, then return to this User's Guide for the steps to scan.

**NOTE:** You can access the TWAIN interface when you're scanning from the One Touch software. If the One Touch configuration you are using is set to **Configure Before Scan**, and the selected option is TWAIN, the TWAIN interface opens right away when pressing the button on your scanner without opening any other TWAIN-compliant software first. See the section "Configure Before Scan" on page 29 for details.

The PaperPort and OmniPage user guides are located on the installation disc you received with the scanner.

The PaperPort software includes a complete set of help topics that answer questions about each feature of the software. To open the Help Topics window, press the **F1** key on your keyboard or choose **PaperPort help** from the Help menu.

# Accessing the TWAIN Interface

## Open the TWAIN interface from One Touch:

If the One Touch configuration you're using to scan is set to **Configure Before Scan**, and the selected option is **TWAIN**, the TWAIN interface opens right away without opening PaperPort first.

For example, the following figure shows the options you would have selected to set up button 1 to open the TWAIN interface.

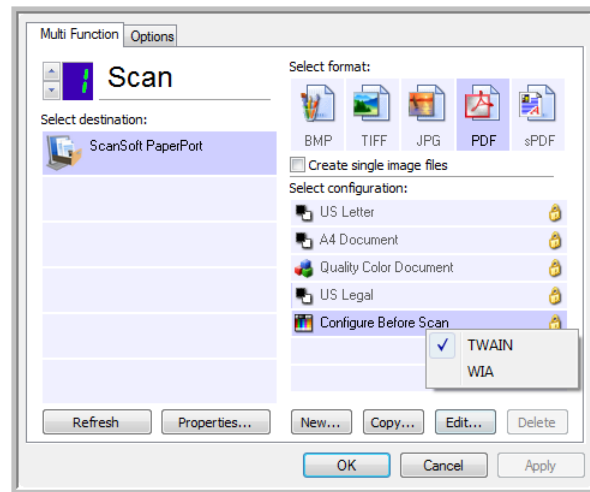

## Open the TWAIN interface from an application:

Please refer to your scanning application's user guide for instructions on accessing the TWAIN interface. Below is a brief list of common applications and how to initiate a scan from within that application, including some of the applications which may have been provided with your scanner.

1. Open a TWAIN-compliant scanning application.
2. Use the application's command that opens the TWAIN interface.

**PaperPort**—On the Tool bar click on the Scanner icon to open the Scan Pane on the left side of the PaperPort desktop. Select your scanner in the Scan Pane then click on the "Scan" button in the Scan Pane.

**ArcSoft PhotoImpression**—Click on the Scanner icon from the main menu.

**Corel Paint Shop Pro**—From the File menu select the Import option to select your scanner model, then from the file menu select the Import function and choose TWAIN Acquire.

**Adobe Software**—Depending on the application you can "Create a file" then select the scanner as your creation source, or "Import a Picture" and select the scanner as your import from source.

**Microsoft Software**—Depending on the application you can go to "Insert Picture... from Scanner or Camera", "File... Scanner or Camera", or "Insert Picture to Clip Organizer from Scanner or Camera".

3. The TWAIN interface opens and you're ready to start scanning.

# The Two TWAIN Interface Options

When scanning with TWAIN, you have two interface options:

- **Basic Interface**—Use the Basic Interface if you don't need to make many adjustments to the image before scanning. You can adjust brightness, contrast, resolution, page size, and picture type. See “Scanning from the TWAIN Basic Interface” on page 56.
- **Advanced Interface**—The Advanced Interface includes all the settings of the Basic Interface, plus a wide range of more advanced settings, such as color saturation, gamma, and hue. See “Scanning from the TWAIN Advanced Interface” on page 58.

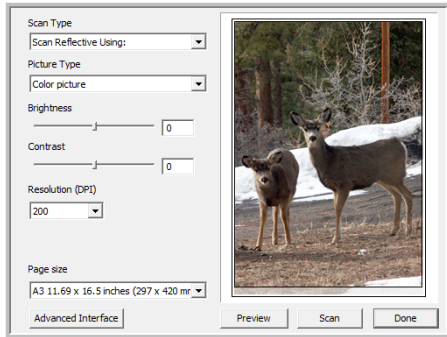

The **Basic Interface** has the settings for scanning typical documents.

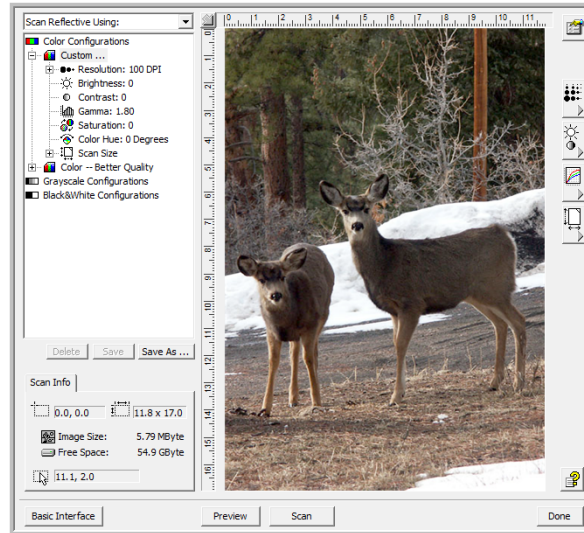

The **Advanced Interface** has all the scan settings of the Basic Interface, plus a range of additional settings for more advanced image adjustment.

To switch between the Basic and Advanced Interfaces, click the **Basic Interface** or **Advanced Interface** button.

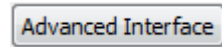
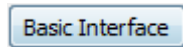



## Scanning from the TWAIN Basic Interface

The Basic Interface can scan a preview of the image so you can adjust its appearance before scanning the final image. After adjusting the appearance, you click the **Scan** button on the Basic Interface to scan.

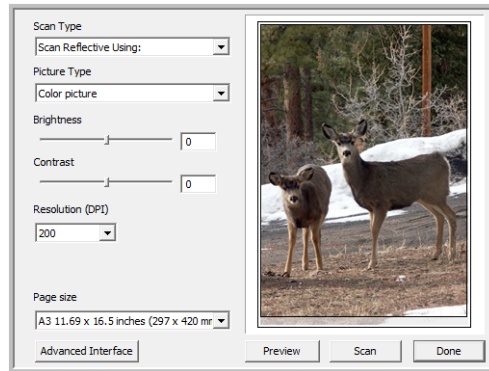

### To scan from the Basic Interface:

1. The **Scan Type** menu's only option is **Scan Reflective Using** for scanning from the flatbed glass.
2. Choose the color, grayscale, or black and white option from the **Picture Type** menu.
3. Choose a resolution from the **Resolution (DPI)** menu.
4. Choose a page size from the **Page Size** menu.
5. Click the **Preview** button.  
The scanner scans the item and displays a preview image.  
You can now use the options on the Basic Interface to adjust the image.
6. Adjust the **Brightness**, **Contrast**, and **Resolution** until the picture is what you want. You can also change the picture type again, for example, from color to grayscale.
7. When you are satisfied with the preview image click **Scan**.
8. When you're finished scanning items, click **Done** to close the Basic Interface.
9. The scanned images will appear in PaperPort, or the other TWAIN application you're using.

## Scanning Part of an Image

To scan part of an image, you draw a box around the part you want. The scanner then only scans that portion of the image and places it in the scanning application.

1. Put the pointer on the image and drag a box around the section of the image that you want to scan.

A dotted outline shows the selected area in the image.

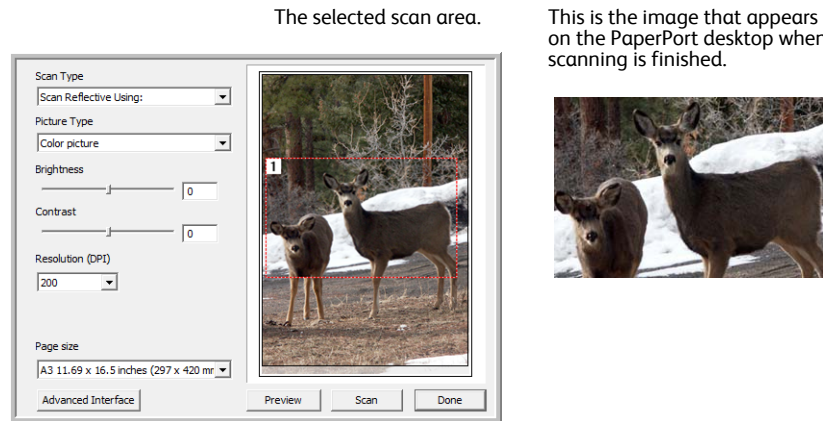

You can now move or resize the outline to select the specific area you want to scan.

2. To move the dotted outline, put the pointer in the selected area and drag the mouse.
3. To resize the area, put the pointer on a dotted line and drag.
4. If you want to remove the selected area and start over, click **Remove**.
5. Click **Scan** when you're ready to scan the portion of the image.

## Scanning from the TWAIN Advanced Interface

The Advanced Interface has more options for scanning than the Basic Interface.

1. Open the TWAIN Interface.
2. If the Basic Interface opens, click the **Advanced Interface** button.

The Advanced Interface opens.

Click an icon to select a configuration—Color, Grey Scale, or Black&White. Clicking the “+” sign in front of Custom shows Custom’s scan settings.

Click a setting in the list to change it. The setting’s options appear on the right side of the Advanced Interface where you can make changes if necessary.

Check the Scan Info to make sure your computer has sufficient space for the image. Warning icons on this box appear if your computer does not have enough space for the scanned image’s file.

If you don’t need all the features of the Advanced Interface, click Basic Interface to return to it.

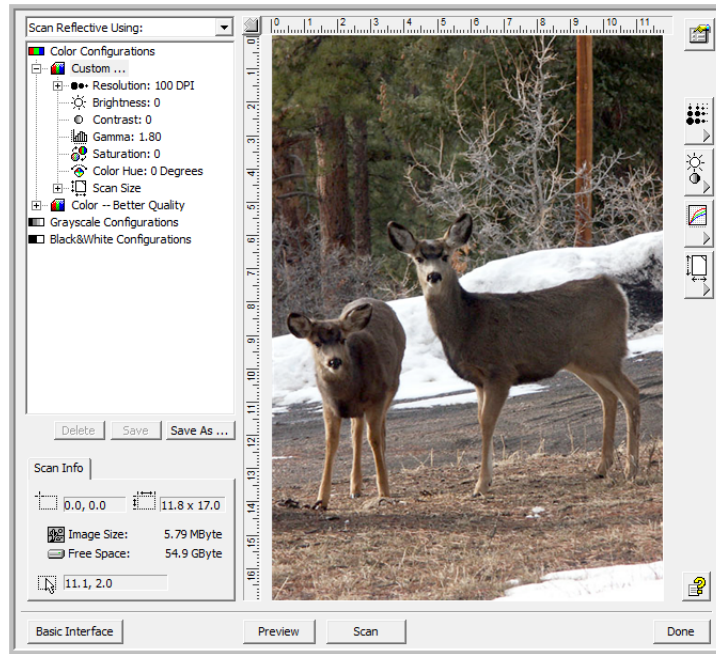

Click Preview to view the image in the window.

When you are satisfied with the scan settings, click Scan.

Click Done to close the Advanced Interface.

3. Click one of the icons to select a configuration.

The configuration settings appear as a list. Click the + (plus) sign to see the full list. Click the - (minus) sign to collapse the list.

- **Color** scans the image in full color. Use this setting to scan color photographs and other color images.
- **Grayscale** scans the image using up to 256 true shades of gray. Use this setting to scan black and white photographs and other higher quality black and white images. You can also scan a color photo with this setting to turn its colors into grey shades.
- **Black&White** is for letters, memos, pen and ink drawings, and other black and white material.

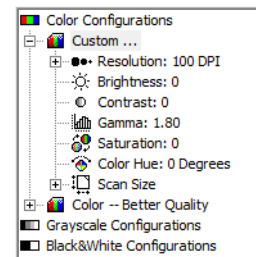

4. Click the **Preview** button to preview the image before scanning.
5. Review the image to determine if adjustments are needed.
6. To adjust a setting, click the setting in the list on the left below the selected configuration. A panel opens on the right side of the Advanced Interface for the selected setting. The next section provides details about the options found in these side panels.
7. When you’re satisfied with the image, click the **Scan** button.
8. When you’re finished scanning items, click **Done** to close the Advanced Interface.
9. The scanned images will appear in PaperPort, or other TWAIN application you’re using.

## Adjusting the Image with the Advanced Interface

You can adjust the scan settings on the Advanced Interface to produce the best possible image for the documents you're scanning.

### To adjust a setting:

1. On the left side of the Advanced Interface, select a configuration.
2. Click a setting in the list of settings, or click its corresponding button on the right side of the Advanced Interface.

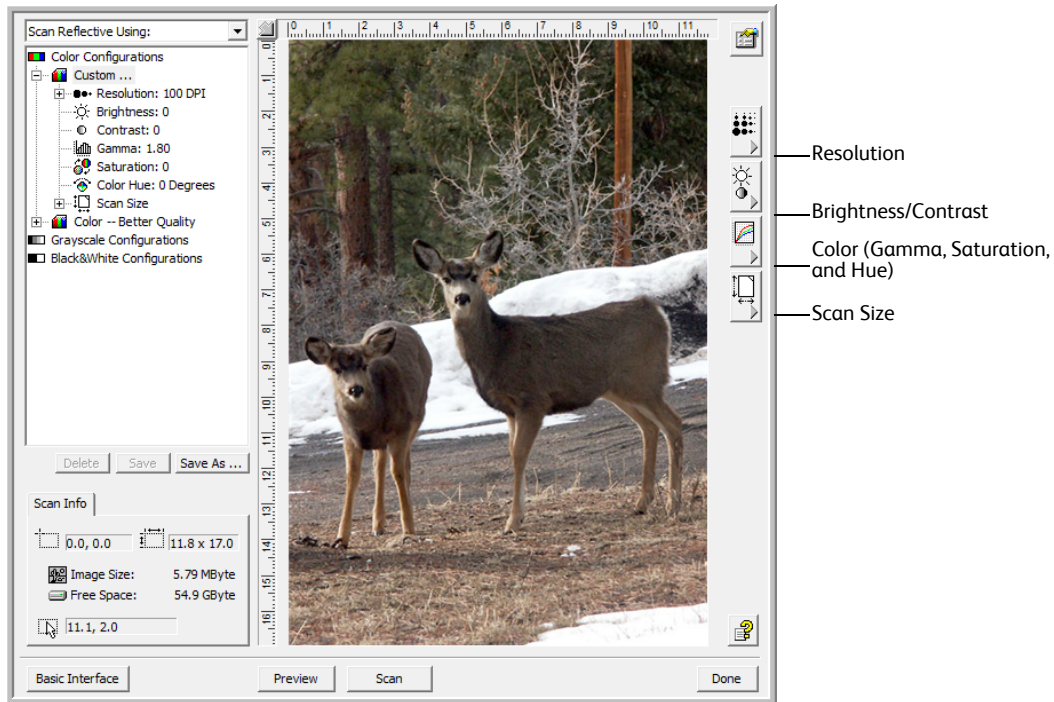

**NOTE:** The list of scan settings for a configuration applies only to that type of configuration. For example, the Black&White Configuration does not have a setting for adjusting the Color Hue.

## Adjusting the Resolution

Resolution determines the amount of detail you can see in the scanned image. The resolution setting for a scan is in dots-per-inch (dpi). The higher the resolution, the finer the details. However, higher dpi settings also take longer to scan and produce larger file sizes. If you are scanning photographs to make copies, 200 dpi will make a direct size copy of similar image quality to the original. You would use a higher dpi setting to enlarge a picture from the original size.

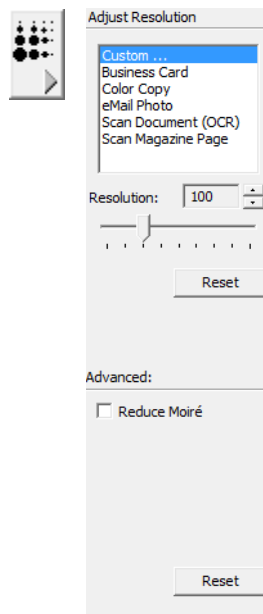

### To adjust the resolution:

1. To use one of the preset resolutions for typical scanned items, click one of the options in the list.
2. To set the resolution manually, drag the **Resolution** slider to the left to decrease the resolution or to the right to increase it.  
You can also click the up and down arrows to increase or decrease the setting.
3. Click **Reset** to return the resolution to its original setting.

The resolution panel also includes an advanced setting for Moiré patterns. Moiré patterns are wavy, rippled lines that sometimes appear on the scanned images of photographs or illustrations, particularly newspaper and magazine illustrations. To scan the image and limit or eliminate moiré patterns, select the **Reduce Moiré** option. This option is not available for high resolution settings.

## Adjusting the Brightness and Contrast

Sometimes an item is scanned with the brightness and contrast set to be too light or too dark. For example, a note written with a light pencil may need to be scanned darker to improve legibility.

Contrast settings are only available for Color and Grayscale configurations.



### To adjust the brightness and contrast:

1. Drag the **Brightness** slider to the left to make the item darker or to the right to make the item lighter.
2. Drag the **Contrast** slider to the left to decrease the contrast or to the right to increase the contrast.  
You can also type a number directly into the brightness or contrast setting boxes, or click the up and down arrows next to the box to increase or decrease the setting.
3. Click **Reset** to return the settings to their original numbers.

## Adjusting Gamma, Saturation, and Color Hue

If you're using the Color Configuration to scan, you can adjust a group of color settings. Gamma controls the brightness of the color midtones.

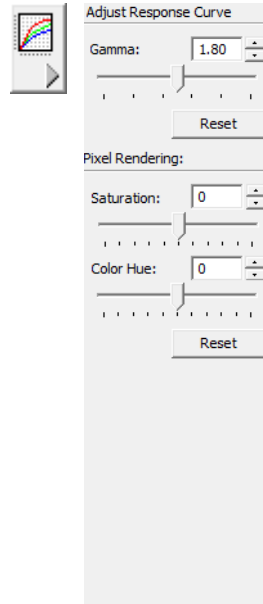

### To adjust the color settings:

1. Drag the **Gamma**, **Saturation**, and **Color Hue** sliders to the left to decrease the settings or to the right to increase the settings.

You can also type a number directly into the setting boxes, or click the up and down arrows next to the boxes.

**Gamma**—is the tone curve and the starting point for image enhancement. As you raise or lower the Gamma value, the values at which Color Saturation, Color Hue, Brightness and Contrast affect the image are changed. It is recommended that you keep the default Gamma value or adjust this setting before adjusting the other options.

**Saturation**—the strength or purity of a color. Adjusting the saturation will affect how “gray” the tones of the color are without changing the overall brightness of the image.

**Color Hue**—the color your eyes see as reflected from the image. It is color in the purest state without black or white. Adjusting the color hue changes the colors without affecting the darkness or lightness of the colors.

2. Click **Reset** to return the settings to their original numbers.

These options do not apply to Black & White scanning and are disabled when the Black & White scanning option is selected.

The Saturation and Color Hue options do not apply to Grayscale scanning and are disabled when the Grayscale scanning option is selected.

## Adjusting Input Size

You can select one of the pre-defined input page size options in the list, or manually set the page size by clicking and dragging a scan area in the preview window.

The following figure shows the input size options.

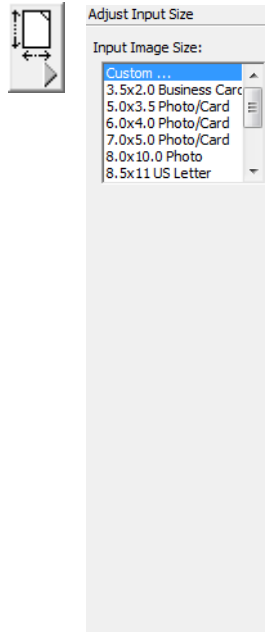

### To manually set the image size:

1. Place an item on the scanner glass and click **Preview** in the TWAIN interface.
2. In the previewed image, click and drag a box around the area you want to scan.
3. The dotted outline shows the selected area in the image.
4. You can now move or resize the outline to select the specific area you want to scan.  
To move the dotted outline, put the pointer in the selected area, then click and drag the mouse.  
To resize the selected area, put the pointer on a dotted line, then click and drag the mouse.
5. If you want to remove the selected area and start over, click **Remove** on the Scan Info box.
6. When the settings are what you want, click **Scan**.



This example shows a manually selected area.

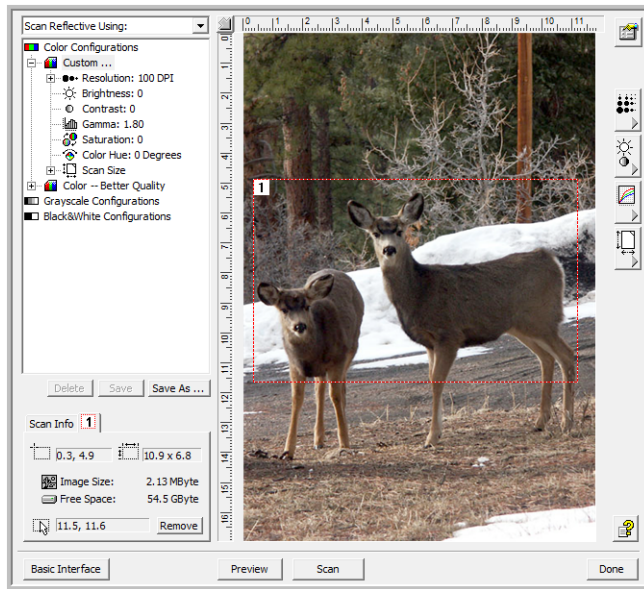

This is the image that appears on the PaperPort desktop when scanning is finished.

The Scan Info box shows the size and position of the area.

### The Ruler Units

The ruler around the edges of the image help you precisely position a custom sized image. You can change the ruler units to suit the type of measurements you want. 

Click the **Ruler Units** button.

The ruler units across the top and down the side of the window cycle through centimeters, inches, and pixels.

### The Scan Info Box

The following figure shows the information on the Scan Info box.

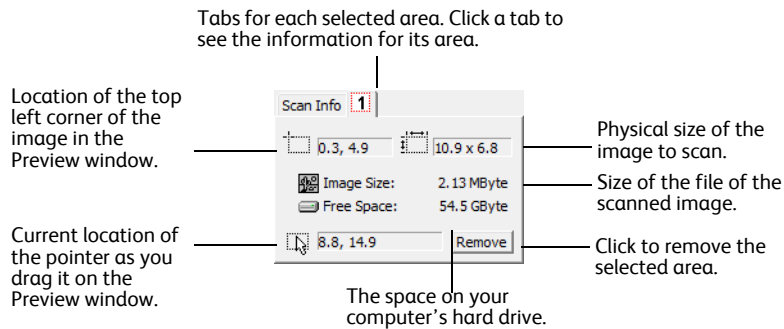

## Creating a New Advanced Interface Profile

You cannot change the settings of the preset profiles in the Advanced Interface. However, you can create new profiles and save them for future use.

### To create a new profile:

1. On the Advanced Interface, select one of the preset profiles, for example, Black&White Configurations/Custom.
2. Adjust the settings as required and then click the **Save As** button.  
The Save Profile dialog box opens.

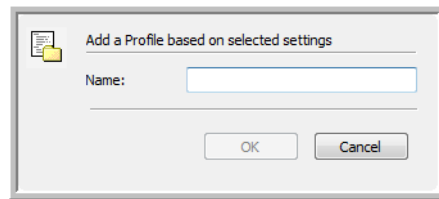

3. Type a name for the new profile and click **OK**. The name must be at least two characters long.  
Your new profile is added to the configuration list.

### To change or delete a profile you created:

1. Select your profile from the configuration list.
2. Make changes to the profile as needed, and then click **Save**.
3. If you want to delete the selected profile, click **Delete**.

## Connect to Another Scanner

You can link with other Xerox desktop scanners to add the functionality of the second scanner to the DocuMate 700 TWAIN interface. You select the scanner to connect to from the Device Configuration Properties window. This window also shows the hardware information about your scanner.

1. Install the driver for the Xerox desktop scanner you want to connect the DocuMate 700 with. For example, if you have a Xerox DocuMate 262i, install the driver for that scanner before proceeding with these instructions.

For a list of scanners the DocuMate 700 will connect to, please visit the DocuMate 700 product support page at [www.xeroxscanners.com](http://www.xeroxscanners.com).

2. At the end of the DocuMate 262i scanner driver installation, you will be prompted to plug the scanner into the computer and a wall outlet. Follow the instructions on screen for connecting the power supply to the scanner and to a wall outlet, but use the diagram below as a guide to connect the USB cable for the DocuMate 262i to the DocuMate 700.

Make sure the DocuMate 700 power is turned on before proceeding.

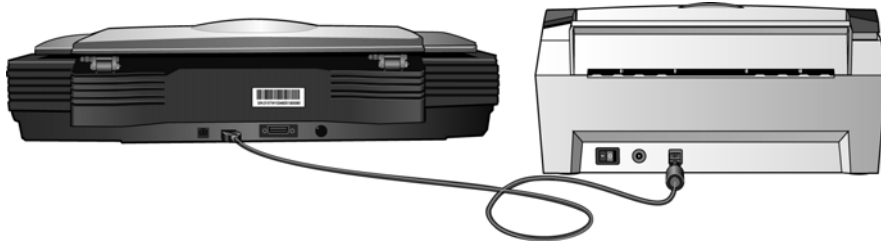

3. Open a TWAIN scanning application. The instructions in this section briefly describe scanning from the PaperPort software.
4. Click on the scan icon on the PaperPort tool bar.



5. If this is the first time PaperPort has been opened, you will automatically be prompted to select a scanner. If this prompt does not open, click on the **Select...** button to open the select scanner window.
6. Select the **TWAIN: Xerox DocuMate 700 Combo** scanner then click on OK.

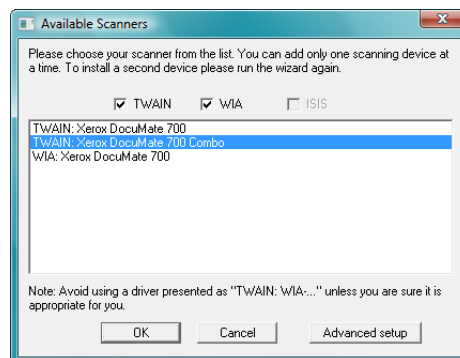

7. Click on the **Scan** button in the PaperPort scan pane.
8. When the TWAIN interface opens, click on the **Advanced Interface** button.



9. Click on the Device Configuration Properties button to open the hardware device options for your scanner.



10. Click on the menu next to **Combine with**. Select the scanner you want to use with the DocuMate 700, in this example the other installed scanner is the DocuMate 262i.

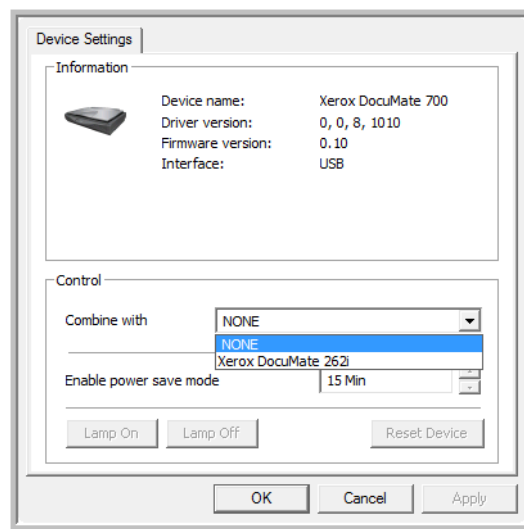

**NOTE:** The options to turn the scanner lamp on or off are disabled when opening the Device Configuration window from TWAIN. If you want to change the settings for the lamp, please refer to “Checking the Hardware and Setting the Lamp Power Saving” on page 51.

11. Click on **OK**.
12. Click **Done** in the TWAIN interface.
13. Click on the **Scan** button in the PaperPort scan pane to reopen the TWAIN interface.

14. The TWAIN interface will open and the Scan Type list will include scanning Simplex or Duplex from the DocuMate 262i.

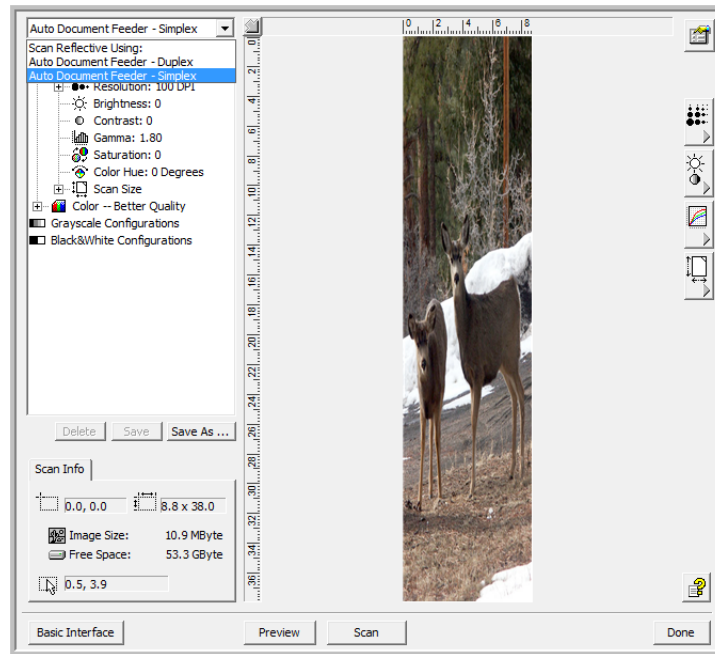

## Scanning from the Automatic Document Feeder

After you have selected to combine with another scanner, such as the DocuMate 262i, the TWAIN interface will include options for both the DocuMate 700 and the other scanner you selected.

1. Open the TWAIN interface.
2. In the Scan Type list, select Auto Document Feeder – Simplex to scan single-sided pages from the 262i, or select Auto Document Feeder – Duplex to scan double-sided pages from the 262i.

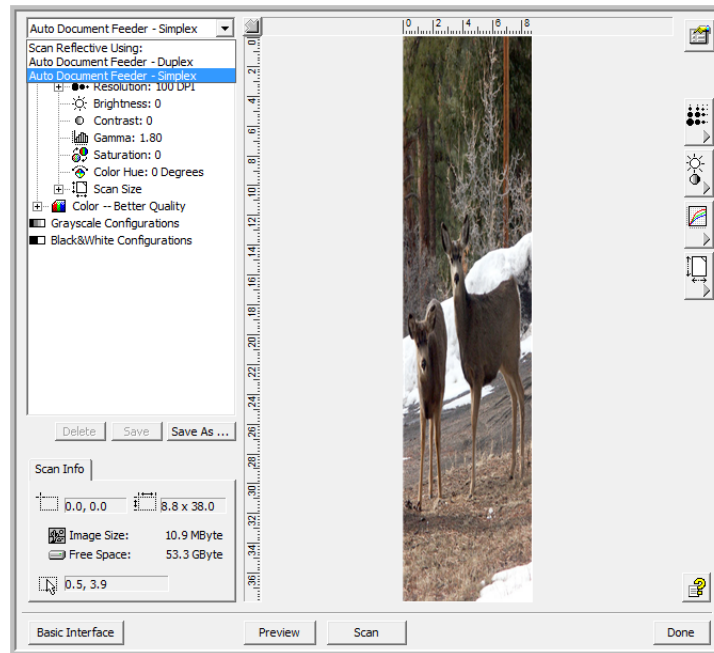

3. Adjust the paper guides on the DocuMate 262i for the width of the documents being scanned.
4. Place the documents *face down* in the DocuMate 262i paper input tray.

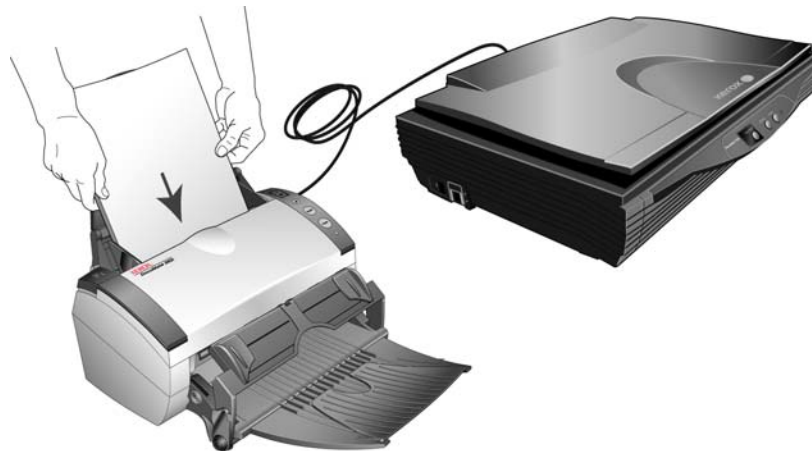

- From the Advanced TWAIN Interface, click on the page size button to expand the panel for selecting from a list of default page sizes.

Make sure one of the **Auto Document Feeder** options is selected as the Scan Type, the options in the Page Size lists are specific to the page sizes the DocuMate 262i supports. If **Scan Reflective Using** is selected as the Scan Type, then the page sizes available in this panel are specific to the page sizes the DocuMate 700 supports.

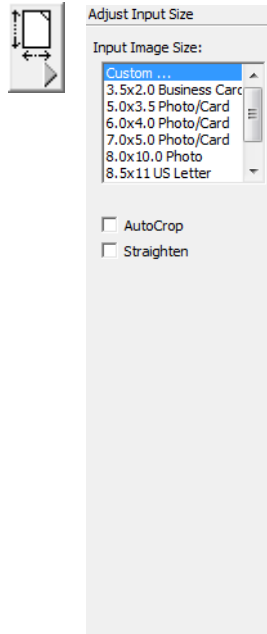

From the Basic TWAIN Interface, click on the menu under Page Size and select an option from the list.

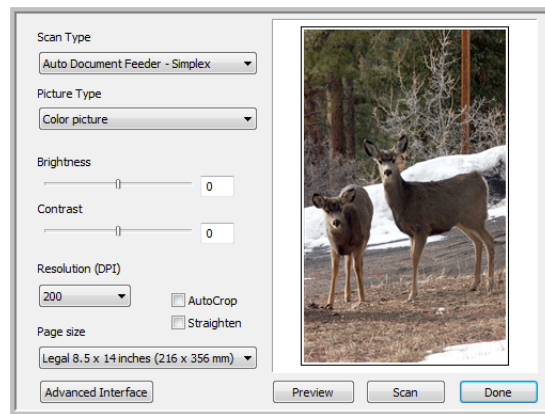

6. Click on the **Scan** button to start scanning the pages in the DocuMate 262i.

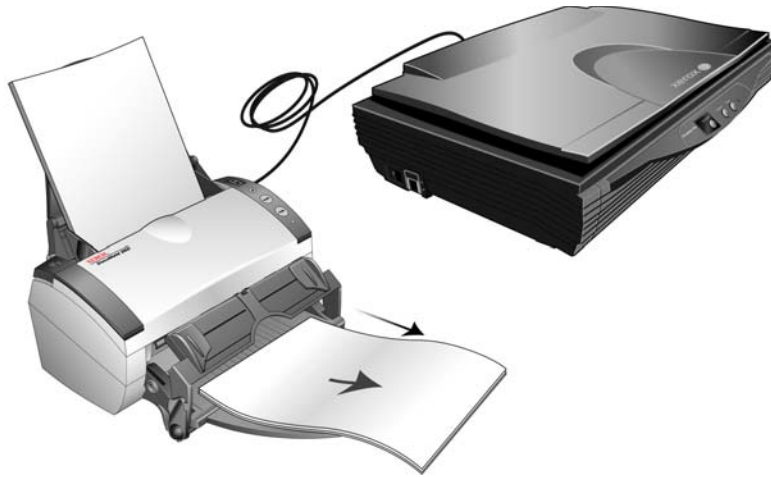

If Scan Reflective Using is selected for the Scan Type, the scanner will automatically scan from the DocuMate 700.

7. When scanning is finished, click on the **Done** button in the TWAIN interface and the scanned documents will be available in the TWAIN application you are using.





# Scanning from WIA

# 4

Microsoft Windows XP and Windows Vista include their own scanning interface—known as Windows Image Acquisition (WIA)—for acquiring images from scanners, digital cameras, and other digital devices.

This section shows how to use Microsoft Paint to scan using the WIA interface, but you can use PaperPort and other Windows applications as well.

## To scan using WIA from Microsoft Paint:

1. On the Windows taskbar, click **Start**, point to **Programs**, point to **Accessories**, and then click **Paint**.
2. From the **File** menu choose **From Scanner or Camera**.

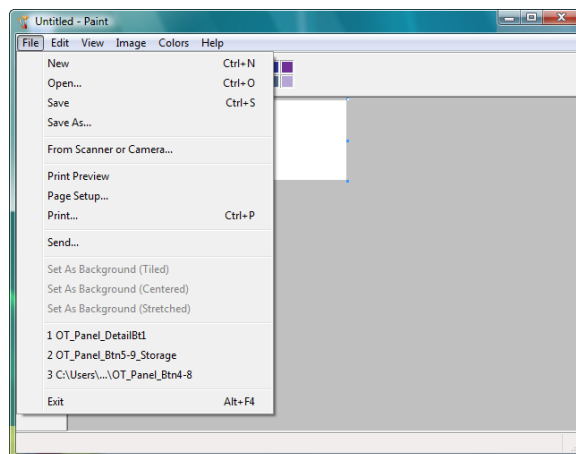

3. The scan window opens. Use this window to select scanning options and start the scan process.

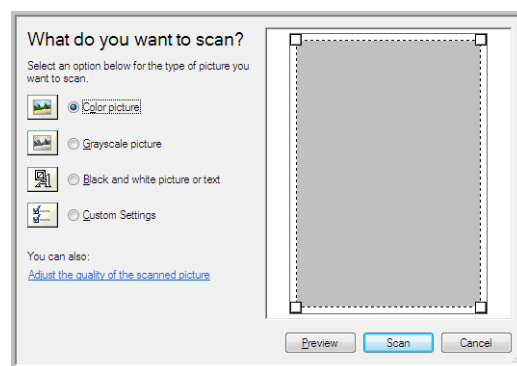

4. Click on the color mode appropriate for the item you are scanning.
5. Place a document in the scanner.

6. Click on the **Scan** button in the WIA interface.  
The scanner starts scanning.
7. The scanned image will appear in Microsoft Paint (or other WIA application you're using).

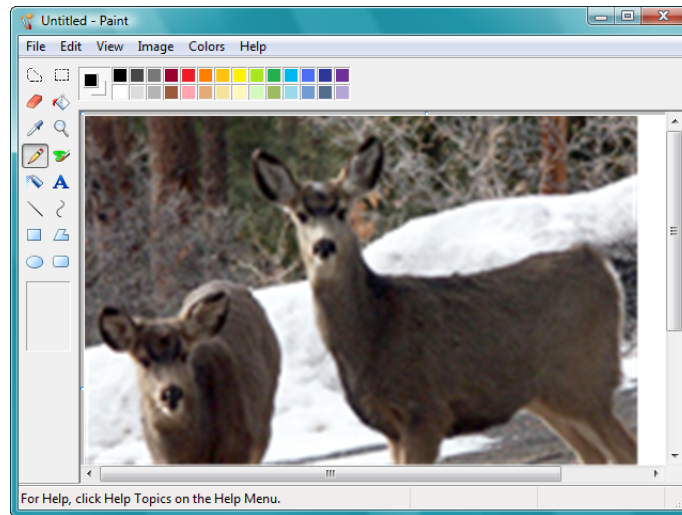

**NOTE:** Windows Vista has advanced options available for scanning with the WIA interface. Scanning from Microsoft's Paint application uses the interface described in this section. Other applications may access the advanced WIA interface available with Windows Vista. Please refer to the Windows help for instructions on using WIA.

## Fine Tuning Your Scans

You can select new settings before you scan an item to fine tune exactly how you want to scan it.

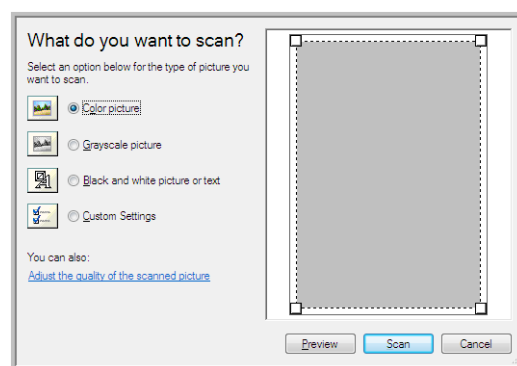

1. On the scan window, click **Adjust the quality of the scanned picture**.

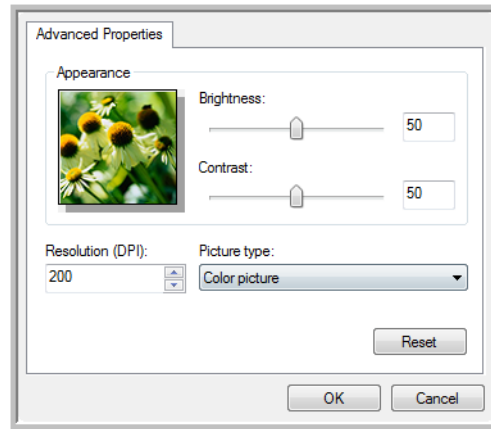

2. Select the options for scanning.  
**Brightness** and **Contrast**—Drag the sliders to the right or left to adjust the brightness and contrast of the scanned image.  
**Resolution (DPI)**—Click the up or down arrow to scroll through the dots per inch (dpi) of the resolution. Higher dpi settings take longer to scan and produce larger files for the scanned images.  
**Picture type**—Click the menu arrow and choose the most appropriate type for the item you're scanning.
3. Click **OK**.  
The Custom Settings button is now set to scan with the options you selected.



# Scanning from ISIS

# 5

You can use the ISIS interface from QuickScan or any other application that will access the ISIS driver. You received QuickScan with your scanner.

Note that the ISIS interface for each application varies depending on the application. Please refer to that software application's User Guide for instructions on scanning the ISIS interface. The QuickScan User's Guide is available on the installation disc that you received with the scanner.

## Accessing the ISIS Interface in QuickScan

Open the QuickScan software to access the ISIS driver scanning options. Please note that you may see the following warning message:



1. Please disregard the message and click **Continue**.  
The ISIS drivers were installed correctly during the installation of your scanner.  
The Scanner Selection dialog box will then appear.
2. Select **Xerox DocuMate 700** from the list of scanners and click **OK**.  
Your scanner is then ready to work with the ISIS driver.



# Maintenance

# 6

This section contains information about maintenance, troubleshooting, uninstalling, scanner specifications, and spare parts.

## Cleaning the Scanner Glass

Scanning items that have excessive amounts of dirt or dust may dirty the glass. To ensure the best quality scanned item, wipe the scanner glass with a soft clean cloth to rid the glass of dust or other debris.

## Troubleshooting

In addition to the troubleshooting information contained in this section, please see the Readme file on your installation disc. The Readme file contains additional information that may help you diagnose problems with the scanner. Also visit our web site at [www.xeroxscanners.com](http://www.xeroxscanners.com) for additional technical information.

### **Problem: The scanner won't scan. What's wrong?**

Check for one of these possible problems:

- **Is a cable loose or not plugged in securely?** Inspect all cable connections. Make sure all the cables are plugged in securely.
- **Is the scanner's status light on?** Turn on the scanner's power. If the status light doesn't come on, plug the power supply into another electrical outlet.
- **Is the scanner's locking tab in the locked position?** Slide the locking tab to the unlocked position. If you tried to scan with the scanner locked, you need to turn off the scanner then turn it back on again. If this does not resolve the problem, try restarting your computer.
- **Did you restart the computer after installing the software?** If you didn't restart the computer, it may not have loaded all of the software files. Try restarting your computer.
- **Do you plug the scanner into a USB hub?** Try plugging the scanner directly into a USB port on the computer.
- **Did you select another TWAIN source for acquiring images?** If you use multiple TWAIN devices with your computer, you may have selected another source for images. Make sure **TWAIN:Xerox DocuMate 700** is selected as your scanner.



**Problem: I got the error message: PaperPort cannot allocate enough memory to perform internal critical operations.**

Close any other active applications so that additional memory is available. If you click Continue, PaperPort moves the file to the PaperPort data directory and renames the file with the prefix "bad." This allows you to recover the file later. To recover the file, import it into PaperPort by using the Import command in the File menu.

**Problem: The installation will not complete successfully.**

A likely cause is that some driver programs are already installed on your computer for another scanner. They are interfering with the installation and One Touch options, and you need to remove those other drivers and re-install your Xerox DocuMate 700 scanner. Please see the documentation that you received with the other scanner for the steps to remove its driver programs. After uninstalling the other scanner's driver programs, uninstall One Touch 4.0 using the steps on page 82, then reinstall it using the steps on page 2.

**Problem: My computer keeps giving me out of hard drive space error messages.**

The minimum requirement of 350MB free hard drive space is for the installation of the software and basic, low resolution, scanning. High resolution scans result in files that can be over 1 gigabyte in size. Free up some space on your hard drive for the software to be able to save the scanned images.

**Problem: If the USB cable is disconnected during a scan, the scanner does not reconnect when the USB cable is plugged back in.**

Unplug the power cable from the scanner, and then plug it back in.

If the scanner does not reconnect:

1. Unplug the power cable from the scanner.
2. Restart your computer.
3. After the restart is complete, plug the power cable back in.

## Error Light Troubleshooting Codes

The status light indicates the current state of the scanner. Descriptions of the most common patterns are listed below. Contact Xerox Technical Support if you experience a different blinking pattern.

### Normal Operation

- **Blinking blue:** indicates the scanner is waking up from power saving and preparing to scan.
- **Steady blue:** indicates the scanner is ready to scan.
- **Steady red:** indicates that the scanner is busy.

### Error Codes

If your scanner experiences hardware problems, the status light will blink red, and the LED flashes an “E” then the error code number.

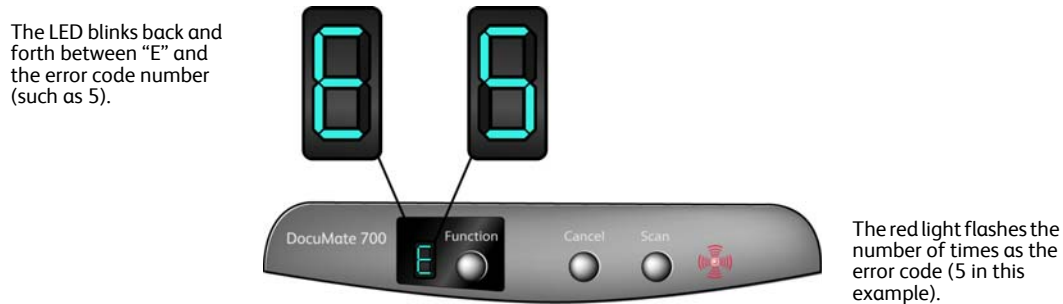

In all cases you should turn off the scanner and check the scanner setup. Verify the scanner lock is in the **unlocked** position, and that the computer and scanner are plugged into a working electrical outlet.

Error Code	Problem Description	Solution
4	The scanner is not communicating with the computer.	If the USB cable is plugged into a USB hub, try plugging the USB cable directly to the back of the computer. If the USB cable is already plugged to the computer, try another USB port on the computer. If the problem persists, replace the USB cable. The maximum length of the USB cable is 6 feet.
5	The lamp in the scanner body has malfunctioned.	This usually occurs if the power was disconnected during a scan. Turn the scanner off, then back on again. If the problem persists, turn off the scanner, re-start the computer, then turn the scanner on.
9	Scanner is locked.	Make sure the scanner lock is in the unlocked position before the scanner’s power is turned on. See the illustration on page 7 for the location of the lock.
All Other Codes	An internal part in the scanner may have malfunctioned.	Turn off the power to your scanner, then turn it back on. If the problem persists, re-boot your computer. If the problem still persists, contact Xerox Technical Support.

# Uninstalling Your Scanner

To uninstall the Xerox DocuMate 700 scanner, remove the scanner software, PaperPort, or any other scanning software provided with the scanner.

## Uninstalling the Scanner and One Touch Software

1. On the Windows taskbar, click **Start**, point to **Settings**, then click **Control Panel**.
2. *Windows 2000 and Windows XP:* Double-click the **Add/Remove Programs** icon.  
*Windows Vista:* Double-click the **Programs and Features** icon.
3. From the list of programs, select **One Touch 4.0**.  
Click the **Change/Remove** button.
4. Click **Yes** when asked to confirm that you want to remove these software programs.
5. Follow these same steps to select and remove the **One Touch 4.0 ScanSoft OmniPage OCR** module from the installed programs list.
6. The One Touch 4.0 software is removed from your computer.
7. **Unplug the USB cable from the scanner.**
8. Close all open windows and restart your computer.

## Uninstalling the PaperPort and OmniPage Software



1. On the Windows taskbar, click **Start**, point to **Settings**, then click **Control Panel**.
2. *Windows 2000 and XP:* Double-click the **Add or Remove Programs** icon.  
*Windows Vista:* Double-click the **Programs and Features** icon.
3. Select **PaperPort** or **OmniPage** and click **Remove**.
4. A message window opens, asking if you are sure you want to remove PaperPort from your computer. Click **Yes**.
5. Close all open windows and restart your computer.

# DocuMate 700 Scanner Specifications

<b>Scanning resolution</b>	600 dpi
<b>Bit depth</b>	24-bit color, 8-bit grayscale, 1-bit line art/text
<b>Maximum item size</b>	Flatbed Mode 11.8 x 17 inches (300 x 432 mm)
<b>Light source</b>	Cold cathode fluorescent lamp
<b>Scan method</b>	Single-pass flatbed
<b>Interface</b>	USB 2.0 High Speed; compatible with USB 1.1
<b>Scanner dimensions</b>	
Width	23.3 inches (592 mm)
Depth	17 inches (432 mm)
Height	5.25 inches (133 mm)
<b>Weight</b>	17 lbs (7.7 kg)
<b>Operating temperature</b>	50°–95° F (10°–35° C without condensation)
<b>Relative humidity</b>	20 %–80 % (@35° C without condensation)
<b>Power adaptor</b>	DC Jack, 3P, 100~240Vac, 24Vdc, 2A, 24W, Class 1, Two Cores, HiTron (HEG42-240200-7L), ENERGY STAR and RoHS compliant
<b>Power consumption</b>	≤ 40 Watts (during operation) ≤ 25 Watts (on standby) ≤ 6 Watts (power save after 15 minutes without scanning, can be adjusted by software) ≤ 1 Watt (power off)
<b>Power cord</b>	US, 3P, 10A/125V, L=1800mm, 3C*18AWG, BLACK, PH8B2EDJF0A- 05B, RoHS  EUR(CEE), 2P+G. BASE, 16A/250V, L=1800mm, 3C*0.75mm <sup>2</sup> , BLACK, PG8B9CIJG0A-05B, RoHS  UK(BS/PSB), 3P, 3A/250V, L=1800mm, 3C*0.75mm <sup>2</sup> , BLACK, PG8B9X3JG0A-05B, RoHS
<b>USB cable</b>	185 cm, 28AWG, with core, RoHS compliant
<b>Safety and agency certifications</b>	UL, C-UL, TUV/GS, FCC Class B, CE, WEEE, RoHS, ENERGY STAR
<b>Supported Operating Systems</b>	Microsoft Windows - 2000 (Service Pack 4), - 32-bit XP (Service Pack 2 or 3) - 32-bit or 64-bit Vista (with or without Service Pack 1)
<b>Scanner Drivers</b>	TWAIN, WIA, ISIS
<b>Bundled Software</b>	Nuance PaperPort® Nuance OmniPage Pro® EMC Captiva QuickScan™

# Xerox DocuMate 700 Parts List

Please use the following part names and numbers when ordering replacements for your DocuMate 700 scanner.

Part Name	Part Number	
USB Cable	35-0118-000	
AC Power Cord	35-0103-000 (US) 35-0104-000 (EUR) 35-0105-000 (UK)	
Power Supply	37-0076-000	

# Appendices

# 7

## Appendix A: Safety Introduction

### Notices and Safety

Please read the following instructions carefully before operating the machine and refer to them as needed to ensure the continued safe operation of your machine.

Your Xerox product and supplies have been designed and tested to meet strict safety requirements. These include safety agency evaluation and certification, and compliance with electromagnetic regulations and established environmental standards.

The safety and environment testing and performance of this product have been verified using Xerox materials only.

**WARNING:** Unauthorized alterations, which may include the addition of new functions or connection of external devices, may impact the product certification. Please contact your Xerox representative for more information.

## Appendix B: EMC

This equipment has been tested and found to comply with the limits for a Class B digital device, pursuant to Part 15 of the FCC Rules. These limits are designed to provide reasonable protection against harmful interference when the equipment is operated in a commercial environment. This equipment generates, uses, and can radiate radio frequency energy and, if not installed and used in accordance with the instruction manual, may cause harmful interference to radio communications.

**WARNING:** In order to allow this equipment to operate in close proximity to Industrial, Scientific and Medical (ISM) equipment, the external radiation from ISM equipment may have to be limited or special mitigation measures taken.

Changes and modifications to this equipment not specifically approved by Xerox may void the user's authority to operate this equipment.

# Appendix C: Operational Safety Information

Your Xerox equipment and supplies have been designed and tested to meet strict safety requirements. These include safety agency examination, approval, and compliance with established environmental standards.

To ensure the continued safe operation of your Xerox equipment, follow these safety guidelines at all times:

## Do These

- Always follow all warnings and instructions that are marked on or supplied with the equipment.
- Before cleaning this product, unplug the product from the USB port. Always use materials specifically designated for this product, the use of other materials may result in poor performance and create a hazardous situation. Do not use aerosol cleaners, they may be explosive and flammable under certain conditions.
- Always exercise care when moving or relocating equipment.
- Always locate the machine on a solid support surface that has adequate strength to support the weight of the machine.
- Always locate the machine in an area that has adequate ventilation and room for servicing.
- Always unplug this equipment from the electrical outlet before cleaning.

**NOTE:** Your Xerox machine is equipped with an energy saving device to conserve power when the machine is not in use. The machine may be left on continuously.

## Do Not Do These

- Never use a ground adapter plug to connect the equipment to a power outlet that lacks a ground connection terminal.
- Never attempt any maintenance function that is not specifically described in this documentation.
- Never remove covers or guards that are fastened with screws. There are no operator serviceable areas within these covers.
- Never locate the machine near a radiator or any other heat source.
- Never override or “cheat” any of the electrical or mechanical interlock devices.
- Never place this equipment where people might step on or trip on the power cord.

# Appendix D: Electrical Information

## Warning - Electrical Safety Information

1. The power receptacle for the machine must meet the requirements stated on the data plate on the rear of the machine. If you are not sure that your electrical supply meets the requirements, please consult your local power company or an electrician for advice.
2. The socket outlet shall be installed near the equipment and shall be easily accessible.
3. Use the power cable that is supplied with your machine. Do not use an extension cord or remove or modify the power cord plug.
4. Plug the power cable directly into a correctly grounded electrical outlet. If you are not sure whether or not an outlet is correctly grounded, consult an electrician.
5. Do not use an adapter to connect any Xerox equipment to an electrical outlet that lacks a ground connection terminal.
6. Do not place this equipment where people might step or trip on the power cable.
7. Do not place objects on the power cable.
8. Do not override or disable electrical or mechanical interlock devices.
9. Do not push objects into slots or openings on the machine. Electrical shock or fire may result.

## Electrical Supply



1. This product shall be operated from the type of electrical supply indicated on the product's data plate label. If you are not sure that your electrical supply meets the requirements, please consult your local power company for advice.
2. **WARNING:** This equipment must be connected to a protective earth circuit. This equipment is supplied with a plug that has a protective earth pin. This plug will only fit into an earthed electrical outlet. This is a safety feature. If you are unable to insert the plug into the outlet, contact your electrician to replace the outlet.
3. Always connect equipment to a correctly grounded power outlet. If in doubt, have the outlet checked by a qualified electrician.

## Disconnect Device

The power cable is the disconnect device for this equipment. It is attached to the back of the machine as a plug-in device. To remove all electrical power from the equipment, disconnect the power cable from the electrical outlet.



## Appendix E: Emergency Power Off

If any of the following conditions occur, turn off the machine immediately and **disconnect the power cable(s) from the electrical outlet(s)**. Contact an authorized Xerox Service Representative to correct the problem:

- The equipment emits unusual odors or makes unusual noises.
- The power cable is damaged or frayed.
- A wall panel circuit breaker, fuse, or other safety device has been tripped.
- Liquid is spilled into the machine.
- The machine is exposed to water.
- Any part of the machine is damaged.

## Appendix F: Maintenance Information

1. Any operator product maintenance procedures will be described in the user documentation supplied with the product.
2. Do not carry out any maintenance on this product which is not described in the customer documentation.
3. Do not use aerosol cleaners. The use of cleaners that are not approved may cause poor performance of the equipment, and could cause a dangerous condition.
4. Use supplies and cleaning materials only as directed in this manual.
5. Do not remove covers or guards that are fastened with screws. There are no parts behind these covers that you can maintain or service.
6. Do not perform any maintenance procedures unless you have been trained to do them by an authorized local dealer or unless a procedure is specifically described in the user manuals.

## Appendix G: Product Safety Certification

This product is certified by the following Agency using the Safety standards listed:

Agency	Standard
Underwriters Laboratories Inc.	UL60950-1 1st (2003) First Edition (USA/Canada)
TUV	IEC60950-1: 2001 First Edition

## Appendix H: Regulatory Information

### Certifications in Europe

#### CE

The CE mark applied to this product, symbolizes XEROX's declaration of conformity with the following applicable European Union Directives, as of the dates indicated:

December 12, 2006:	Council Directive 2006/95/EC as amended. Approximation of the laws of the member states related to low voltage equipment.
December 31, 2004:	Council Directive 2004/108/EC as amended. Approximation of the laws of the member states related to electromagnetic compatibility.

A full declaration of conformity, defining the relevant directives and referenced standards, can be obtained from your XEROX Limited representative or by contacting;

Environment, Health and Safety  
 The Document Company Xerox  
 Bessemer Road  
 Welwyn Garden City  
 Herts  
 AL7 1HE  
 England, Telephone +44 (0) 1707 353434

## Appendix I: Compliance Information

### Product Recycling & Disposal: USA & Canada

Xerox operates a worldwide equipment take back and reuse/recycle program. Contact your Xerox sales representative (1-800-ASK-XEROX) to determine whether this Xerox product is part of the program. For more information about Xerox environmental programs, visit: [www.xerox.com/environment.html](http://www.xerox.com/environment.html).

If you are managing the disposal of your Xerox product, please note that the product contains lamp(s) with mercury, and may contain lead, Perchlorate and other materials whose disposal may be regulated due to environmental considerations. The presence of these materials is fully consistent with global regulations applicable at the time that the product was placed on the market. For recycling and disposal information, contact your local authorities. In the United States, you may also refer to the Electronic Industries Alliance web site: <http://www.eiae.org/>.

Perchlorate Material - This product may contain one or more Perchlorate-containing devices, such as batteries. Special handling may apply, please see: <http://www.dtsc.ca.gov/hazardouswaste/perchlorate/>.

## European Union

### RoHS and WEEE Compliance

This product is compliant with RoHS Regulations of the European Parliament and Council Directive on the Restrictions of the Use of Certain Hazardous Substances in Electrical and Electronic Equipment (2002/95/EC), and with the Waste Electrical and Electronic Equipment (WEEE) Directive (2002/96/EC).

Some equipment may be used in both a domestic/household and a professional/business application.

### Professional/Business Environment

Application of this symbol on your equipment is confirmation that you must dispose of this equipment in compliance with agreed national procedures. In accordance with European legislation, end of life electrical and electronic equipment subject to disposal must be managed within agreed procedures.



# Appendix J: Illegal Copies

## USA

Congress, by statute, has forbidden the reproduction of the following subjects under certain circumstances. Penalties of fine or imprisonment may be imposed on those guilty of making such reproductions.

1. Obligations or Securities of the United States Government, such as:

Certificates of Indebtedness	National Bank Currency
Coupons from Bonds	Federal Reserve Bank Notes
Silver Certificates	Gold Certificates
United States Bonds	Treasury Notes
Federal Reserve Notes	Fractional Notes
Certificates of Deposit	Paper Money

Bonds and Obligations of certain agencies of the government, such as FHA, etc.

Bonds. (U.S. Savings Bonds may be photographed only for publicity purposes in connection with the campaign for the sale of such bonds.)

Internal Revenue Stamps. (If it is necessary to reproduce a legal document on which there is a canceled revenue stamp, this may be done provided the reproduction of the document is performed for lawful purposes.)

Postage Stamps, canceled or uncanceled. (For philatelic purposes, Postage Stamps may be photographed, provided the reproduction is in black and white and is less than 75 % or more than 150 % of the linear dimensions of the original.)

Postal Money Orders.

Bills, Checks, or Drafts of money drawn by or upon authorized officers of the United States.

Stamps and other representatives of value, of whatever denomination, which have been or may be issued under any Act of Congress.

2. Adjusted Compensation Certificates for Veterans of the World Wars.
3. Obligations or Securities of any Foreign Government, Bank, or Corporation.
4. Copyrighted material, unless permission of the copyright owner has been obtained or the reproduction falls within the "fair use" or library reproduction rights provisions of the copyright law. Further information of these provisions may be obtained from the Copyright Office, Library of Congress, Washington, D.C. 20559. Ask for Circular R21.
5. Certificates of Citizenship or Naturalization. (Foreign Naturalization Certificates may be photographed.)
6. Passports. (Foreign Passports may be photographed.)
7. Immigration Papers.
8. Draft Registration Cards.
9. Selective Service Induction Papers that bear any of the following Registrant's information:
 

Earnings or Income	Dependency Status
Court Record	Previous military service
Physical or mental condition	

Exception: U. S. Army and Navy discharge certificates may be photographed.

10. Badges, Identification Cards, Passes, or Insignia carried by military personnel, or by members of the various Federal Departments, such as FBI, Treasury, etc. (unless photograph is ordered by the head of such department or bureau.)
11. Reproducing the following is also prohibited in certain states: Automobile Licenses — Drivers' Licenses — Automobile Certificates of Title.

The above list is not all inclusive, and no liability is assumed for its completeness or accuracy. In case of doubt, consult your attorney.

## Canada

Parliament, by statute, has forbidden the reproduction of the following subjects under certain circumstances. Penalties of fines or imprisonment may be imposed on those guilty of making such copies.

1. Current bank notes or current paper money.
2. Obligations or securities of a government or bank.
3. Exchequer bill paper or revenue paper.
4. The public seal of Canada or of a province, or the seal of a public body or authority in Canada, or of a court of law.
5. Proclamations, orders, regulations or appointments, or notices thereof (with intent to falsely cause same to purport to have been printed by the Queen's Printer for Canada, or the equivalent printer for a province).
6. Marks, brands, seals, wrappers or designs used by or on behalf of the Government of Canada or of a province, the government of a state other than Canada or a department, board, Commission or agency established by the Government of Canada or of a province or of a government of a state other than Canada.
7. Impressed or adhesive stamps used for the purpose of revenue by the Government of Canada or of a province or by the government of a state other than Canada.
8. Documents, registers or records kept by public officials charged with the duty of making or issuing certified copies thereof, where the reproduction falsely purports to be a certified copy thereof.
9. Copyrighted material or trademarks of any manner or kind without the consent of the copyright or trademark owner.

The above list is provided for your convenience and assistance, but it is not all inclusive, and no liability is assumed for its completeness or accuracy. In case of doubt, consult your solicitor.

## Other Countries

Copying certain documents may be illegal in your country. Penalties of fine or imprisonment may be imposed on those found guilty of making such reproductions.

Currency notes

Bank notes and cheques

Bank and government bonds and securities

Passports and identification cards

Copyright material or trademarks without the consent of the owner

Postage stamps and other negotiable instruments

Note: This list is not inclusive and no liability is assumed for either its completeness or accuracy. In case of doubt, contact your legal counsel.

# Appendix K: EH&S Contact Information

## Contact Information

For more information on Environment, Health, and Safety in relation to this Xerox product and supplies, please contact the following customer help lines:

USA:	1-800-828-6571
Canada:	1-800-828-6571
Europe:	+44 1707 353 434



# Index

## A

Actual size, 2-27  
 Add Application, 2-39, 2-40  
 Adobe® Reader®, 1-12  
 Advanced device settings, 2-27  
 Advanced Interface  
   adjust settings, 3-59  
   new profile, 3-65  
   profile, 3-65  
 Advanced Settings tab, 2-25  
 America Online® (AOL), 2-42  
 Apply button, 2-22  
 Aspect ratio, 2-27  
 AutoRotate image, 2-27

## B

bit depth, 6-83  
 Black&White mode, 2-24, 2-25, 3-58  
 blurred image, 3-60  
 BMP file format, 2-31, 2-32, 2-33  
 Brightness, 2-24, 3-61, 4-75  
 Burn to CD, 2-41, 2-44  
   Destination application, 2-44

## C

CD burner, 2-41, 2-44  
 Center image, 2-27  
 Collate copies, 2-27  
 Color Filter, 2-25  
 Color hue, 3-62  
 Color mode, 2-24, 2-29, 3-58, 4-73  
 Color space, 1-5  
 Combine With, 2-52, 3-66  
 Comma Delimited, 2-35  
 Computer specifications, ii-vi  
 Configure Before Scan, 2-22, 2-29, 2-32, 3-53  
   cancel, 2-31  
 Connect to Another Scanner, 3-66  
 Contrast, 2-24, 3-61, 4-75  
 Copy button, 2-22  
 Create copies of scanned documents, 2-37  
 Create single image files, 2-32  
 CSV file format, 2-35

## D

Delete button, 2-22  
 Destination application, 2-18, 2-20, 2-27, 2-28, 2-32, 2-36, 2-47  
   Burn to CD, 2-44  
   Email application properties, 2-42  
   Event Forward (STI), 2-45  
   Image application properties, 2-40  
   Microsoft Explorer (HTML), 2-46  
   OCR, 2-21, 2-43  
   PaperPort properties, 2-38  
   Text application properties, 2-38  
   Text file format, 2-33  
   Transfer to Storage properties, 2-41, 2-44, 2-47  
 Device settings, 2-52  
 Device Settings tab, 2-27  
 DOC file format, 2-35, 2-43  
 Document Management, 2-36  
 Documentation, ii-vi  
 Dots per inch (dpi), 2-24, 2-29, 3-60, 4-75

## E

Edit button, 2-22  
 eMail, 2-36  
 EMC QuickScan™, 1-12  
 error codes, 6-81  
 Event Forward (STI), 2-36, 2-45  
 Excel Spreadsheet, 2-35

## F

Fax and Print, 2-36  
 File format, 2-20, 2-22, 2-29, 2-32, 2-35  
 file storage location, 2-47  
 Fit to page, 2-27  
 Folder Copy Options, 2-37  
 Full install, 1-5

## G

Gamma, 2-26, 3-62  
 GrayScale mode, 2-25  
 Grayscale mode, 2-24, 3-58



**H**

Hardware properties, 2-19  
 Help, ii-vi, 3-53  
 help information, 6-79  
 HTM file format, 2-35, 2-46  
 HTML Document, 2-35  
 HTML page, 2-46  
 Hue, 2-26

**I**

image  
   blur, 3-60  
   preview, 3-58  
 Image Documents Properties, 2-40  
 Image Editors, 2-36  
 Image file formats, 2-33  
 image size, 3-63  
 Improvements and Settings, 2-24  
 input size, 3-63  
 Installation, 1-1  
 Internet Options, 2-42  
 Invert Image, 2-25  
 ISIS Interface, 5-77  
 ISIS only installation, 1-5

**J**

JPG  
   Image quality and file size, 2-33  
 JPG file format, 2-31, 2-32, 2-33

**K**

Key icon, 2-24, 2-29

**L**

Link Properties, 2-37  
 Lock icon, 2-24, 2-29  
 locking tab, 1-7, 6-79  
 Logical Form Recognition, 1-12

**M**

Maintain aspect ratio, 2-27  
 Maximize Quality, 2-33  
 Microsoft Internet Explorer, 2-46  
 Microsoft Outlook, 2-36, 2-42  
 Microsoft Paint, 2-36, 2-40, 4-73  
 Microsoft Word, 2-21, 2-34, 2-35, 2-36, 2-38, 2-43  
 Mini-Guides, 1-14  
 Minimize Size, 2-33

Moiré Patterns, 2-24, 3-60

**N**

New button, 2-22  
 Normal, 2-33  
 Normal PDF (nPDF), 2-35  
 Nuance OmniPage® Pro, 1-12

**O**

OCR options  
   One Touch Mini-Guide, 1-14  
 OmniPage  
   One Touch, 1-14  
 OmniPage® Pro, 1-12, 3-53  
 One Touch  
   Button panel, 2-19  
   icon, 2-18, 2-19, 2-20  
   Install, 1-4  
   New settings, 2-21  
   OmniPage OCR Settings, 2-35  
   Options tab, 2-36  
   Panel features, 2-19  
   properties, 2-20, 2-29, 2-37, 2-43, 2-44, 2-45, 2-47  
   Scan multiple pages, 2-31  
   Scan with TWAIN interface, 3-54  
   VRS Settings, 1-14  
 One Touch Properties window  
   options, 2-23  
 Optical Character Recognition (OCR), 1-14, 2-33, 2-36, 2-38, 2-43  
 Options tab, 2-22, 2-36

**P**

Page Settings tab, 2-24  
 Paper size, 2-24  
 PaperPort desktop, 2-18  
 PaperPort Properties, 2-38  
 PaperPort®, 1-3, 2-36, 3-53, 4-73  
 PDF  
   Image quality and file size, 2-33  
   sPDF and nPDF, 2-35  
 PDF applications, 2-36  
 PDF file format, 2-31, 2-32, 2-33, 2-36  
 Picture type, 4-75  
 Preview button, 3-56  
 preview image, 3-58  
 Properties button, 2-22

## Q

QuickScan, 5-77

## R

Reduce Moiré Patterns, 2-24  
 Refresh button, 2-22  
 Register, 1-11  
 Resolution, 2-24, 2-29, 3-60, 4-75  
 Rich Text Format, 2-35  
 RTF file format, 2-21, 2-35, 2-43  
 ruler units, 3-64

## S

Saturation, 2-26, 3-62  
 Scan configuration, 2-20, 2-26, 2-27, 2-28, 2-48  
     Edit or Delete, 2-29  
     Lock or unlock, 2-24  
     New, 2-23  
 Scan Info box, 3-64  
 Scan multiple pages, 2-31  
 Scan Settings Tab, 2-23  
 Scan to Folder, 2-47  
     Multiple folders, 2-48  
 Scanner  
     connecting, 1-7  
     Device settings, 2-52  
     hardware, ii-vii  
     parts, ii-v  
     uninstall, 6-82  
 Scanner driver, 1-3  
 Scanning mode, 2-22, 2-23, 2-29, 4-73  
 Screen Resolution, 2-40, 2-42  
 Searchable PDF (sPDF), 2-35  
 Select configuration, 2-21  
     Properties, 2-23  
 Select destination, 2-21, 2-36  
 Select format, 2-22  
 Serial number, 1-11  
 SharePoint, 1-14  
 Show all destinations, 2-36  
 Show Hardware, 2-51  
 Show Progress Window, 2-37  
 Simple Text, 2-35  
 Size, 2-24  
 Software, 1-3, 1-12  
 Software help, ii-vi, 1-2, 3-53  
 status light, 6-79  
 Sti event forwarding, 2-36  
 Still Image Client, 2-45  
 Storage and CD-R/W, 2-36

Storage Options tab, 2-28, 2-48  
 System requirements, ii-vi

## T

technical support, 6-79  
 Text Documents Properties, 2-38  
 Text Editors, 2-36  
 Text file formats, 2-33  
 TIFF file format, 2-31, 2-32, 2-33  
 Transfer to Storage, 2-28, 2-47, 2-48  
     file formats, 2-34  
 TWAIN  
     access from One Touch, 3-54  
     Advanced Interface, 3-58  
     Basic Interface, 3-56  
     Open from One Touch, 3-54  
 TWAIN interface, 2-30, 2-31, 2-32, 3-53, 3-54  
 TWAIN only installation, 1-5  
 TWAIN standard, 3-53  
 TXT file format, 2-21, 2-35, 2-43

## U

uninstall, 6-82  
 Updates, 1-11  
 USB cable, 1-8  
 USB port, 1-8  
 Use enhanced folder browser, 2-37  
 User Guides, 1-13

## V

VRS Settings Tab  
     One Touch Mini-Guide, 1-14

## W

Watermark, 2-25  
 Web site for help, 6-79  
 WIA  
     Advanced settings, 4-74  
 WIA interface, 2-30, 4-73  
 Windows Image Acquisition, 4-73  
 Word Document, 2-35

## X

XLS file format, 2-35



